



**SILENCE**<sup>o</sup>  
URBAN ECOMOBILITY

**OWNER'S MANUAL**

**S01** *The  
Ride  
Decision*

## HELL O SILENCER

This is your new S01 electric scooter, equivalent to 125 cc, designed for urban use and 100% *Made in Barcelona*.

The S01 has the best battery of any electric scooter. Created, designed and patented by SILENCE, it is a trolley-type removable battery on wheels that means you are no longer tied to a charging point. The battery can be comfortably, safely taken to any conventional socket: at home, the office, a bar... Anywhere is good and will do for charging it, so you don't have to depend on a specific point or facility.

This model has a top speed of 100 km/h and a battery range of approximately 115 kilometres. This makes it perfect for getting around in the city, with great range and using up to 85% less than a combustion-engine scooter.

The S01 scooter is connected via SIM-App. Designed with advanced technology, the vehicle is always connected to a mobile application developed to give you first-hand information on its status and specifications. You can switch the scooter on or shut it off with the app, with no need for a key, or open the seat and locate the vehicle remotely. Plus, the app gives you real-time information on battery charge levels and how many more kilometres it can go.

A new attractively designed 0-emissions, high-tech scooter for safe, modern, silent urban driving. The best way to accelerate the change towards sustainable urban mobility.

### **Do you dare improve cities with SILENCE?**

Before you start driving your S01 for the first time, please read this owner's manual for your own safety and to prevent any damage to the vehicle or third parties. To service the vehicle, always take it to a SILENCE Official Service Centre.

Enjoy the smooth driving experience, without noise or vibrations.

Thanks for choosing a SILENCE S01!

## ABOUT THIS MANUAL

Please read the whole manual carefully and pay special attention to the safety instructions. It explains everything you need to know as an S01 driver. It should be considered part of the scooter, so if you sell the scooter the manual must go with it.

The information in this manual is the most recent available for this model as of approval for printing/publication. Scutum Logistic S.L. reserves the right to make changes at any time with no prior notice, without taking on any sort of obligation. No part of this manual may be reproduced without written authorisation.

## OTHER MANUALS FOR THIS MODEL

In addition to this document, there are other manuals geared mainly (though not exclusively) to garages:

- a. S01 Spare Parts Catalogue
- b. S01 Maintenance and Service Plan
- c. S01 Torque Tables
- d. S01 Workshop Manual
- e. S01 Manual for Resolving Issues

## SECURITY

Driving a vehicle requires your full attention and can affect your own safety and that of others. So, you are responsible for taking any precautions necessary to minimise risk in using your SILENCE S01.

This section in particular, and the manual in general, offers information and tips to make driving your scooter as safe as possible. However, it can't take into account or warn you of the dangers associated with driving a vehicle and its maintenance. You must use common sense to enjoy your scooter with as little risk as possible. Below you will find some important tips.

### 1. Use and maintenance

The SILENCE S01 is an urban scooter designed to be used on the road only, carrying at most the driver and one passenger. It is also important to respect the maximum load indicated in the corresponding section.

**Respect your limits while driving:** Take into account your personal skills and the road conditions in order to drive safely. Don't overestimate them and leave a margin for the unexpected.

**Don't drink or take drugs before driving:** Your reflexes will be impaired and so will your ability to avoid unexpected hazards. Don't let anyone else drive in that condition either.

**Assess other factors:** Also take into account other factors that affect driving, such as prescription drugs, fatigue or lack of attention.

**Properly maintain the scooter:** Just as you have to be in good shape to drive, it is your responsibility to check and service your scooter before driving, following the instructions in this manual. Inadequate or no maintenance can be a risk factor.

**DISCLAIMER**

The scooter is NOT prepared for regular motorway use, although it can be done sporadically. The vehicle is designed to go at a steady speed of 85 km/h without any critical elements overheating. If the vehicle is used in Sport mode all the time, the battery pack (BP) could overheat. So, SILENCE has developed a system that optimises the vehicle's power use and output to modify settings on the go and avoid this type of issues.

## 2. Clothing and protection

For your safety and that of the passenger, we recommend wearing the right clothing when driving the scooter. Although they do not provide total protection, they can considerably decrease the probabilities of injury and the seriousness of the consequences. Consult a specialist to choose the clothing that best suits you.

**Always wear a helmet:** Proper use of a helmet is basic and obligatory, both for the driver and for the passenger. It must be homologated, in good shape and **properly buckled**. Helmets reduce the number of head injuries and their seriousness. We recommend using **full-face** helmets (that cover the whole head) in **light, bright colours or with reflector strips**, that are lightweight and **fit properly**.

**Protect your eyes:** Always wear eye protection, either the visor of the helmet or appropriate glasses.

**Other garments:** Wear stiff boots and leather gloves, to protect feet, ankles and hands from scratches, cuts and contusions. Wear a suit or jacket and trousers specifically designed for use on a scooter. These should be form-fitting and the right size, and we recommend they have reflector strips.

These recommendations also apply to the passenger, if there is one.

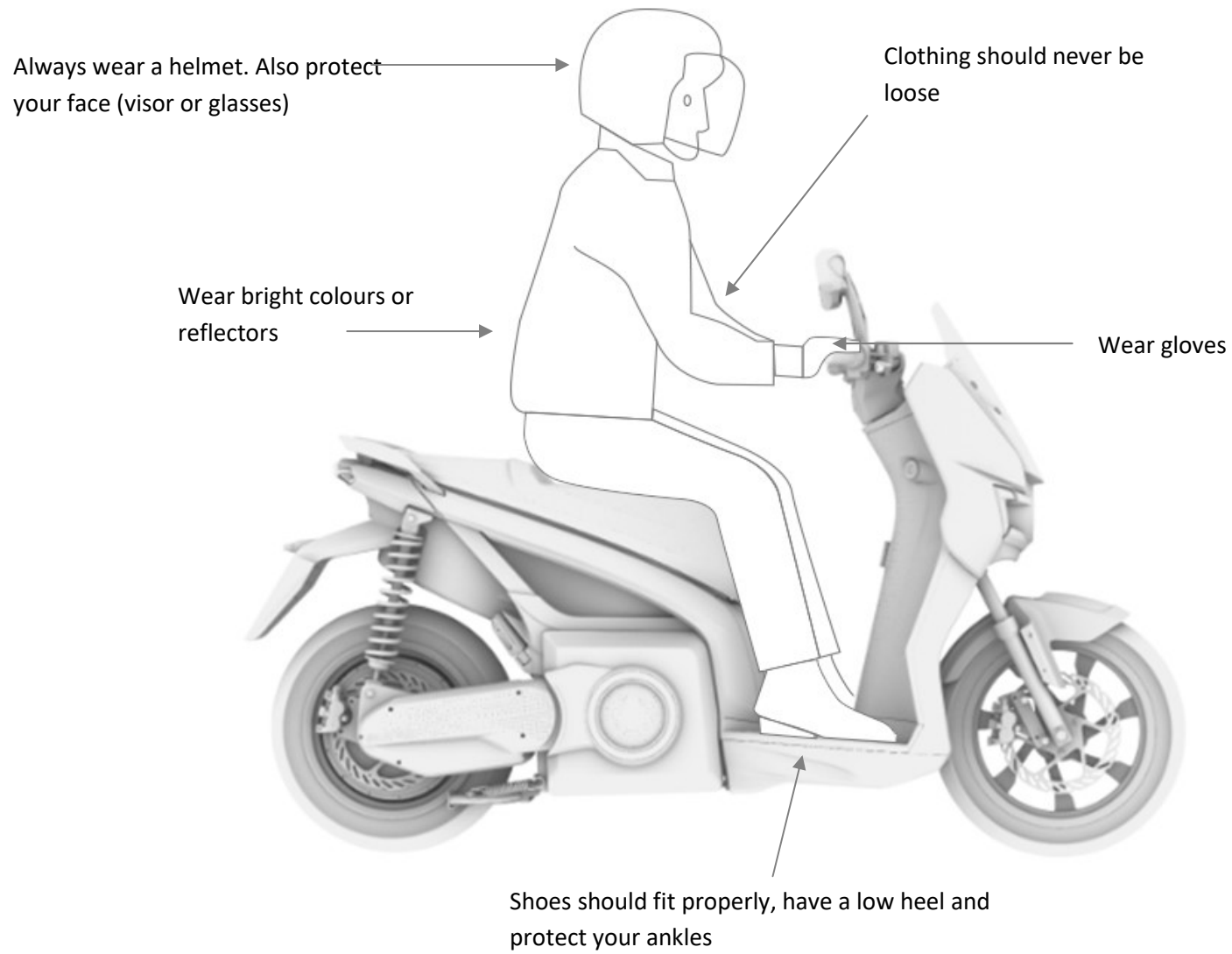

### 3. Load

This scooter is designed to be driven safely as long as the maximum load capacity and proper distribution are respected. Failure to do so may compromise the stability, braking power and manoeuvrability of the scooter.

The maximum mass of the scooter cannot be more than 320 kg, including the vehicle itself with its battery and accessories, the driver and the passenger, when applicable, and any load. The weight carried must be distributed evenly between the two axles, with no more than 102 kg on the front axle and 218 kg on the rear axle.

Remember that the weight of any accessories installed will reduce the additional load that the scooter can carry.

#### IMPORTANT INFORMATION

##### Tips

- Distribute the load evenly on the scooter, and try to keep it as close to the centre as possible.
- Make sure the load is firmly tied down, avoid carrying loose objects.
- Always make sure tyres are properly inflated, and adjust the rear suspension to suit the specific load in each case.

## 4. Accessories and modifications

We recommend using only SILENCE accessories, as they have been designed and tested to ensure they work properly with this model of scooter. If you use other accessories or modify them in any way, you must make sure they are installed and chosen properly so that they:

- Don't obstruct the turning radius of the handlebar or interfere with the use of any of the controls.
- Don't limit the side angle of inclination or distance from the ground.
- Don't interfere with visibility or the beam of any of the lamps.
- Don't affect any electrical or electronic components of the scooter.
- Comply with legal regulations.



# CONTENTS OF THIS MANUAL

|   |                               |
|---|-------------------------------|
| <b>OTHER MANUALS FOR THIS MODEL</b> .....           | ¡Error! Marcador no definido. |
| <b>SECURITY</b> .....                               | ¡Error! Marcador no definido. |
| <b>1. Use and maintenance</b> .....                 | ¡Error! Marcador no definido. |
| <b>2. Clothing and protection</b> .....             | ¡Error! Marcador no definido. |
| <b>3. Load</b> .....                                | ¡Error! Marcador no definido. |
| <b>A. VEHICLE IDENTIFICATION</b> .....              | ¡Error! Marcador no definido. |
| <b>1) VIN Number - chassis number</b> .....         | ¡Error! Marcador no definido. |
| <b>2) Information tag - production plate</b> .....  | ¡Error! Marcador no definido. |
| <b>B. BASIC COMPONENTS</b> .....                    | ¡Error! Marcador no definido. |
| <b>1) Battery pack (be)</b> .....                   | ¡Error! Marcador no definido. |
| <b>2) Motor (rear wheel)</b> .....                  | ¡Error! Marcador no definido. |
| <b>3) Instrument panel</b> .....                    | ¡Error! Marcador no definido. |
| a) LCD screen .....                                 | ¡Error! Marcador no definido. |
| CHARGE GAUGE .....                                  | ¡Error! Marcador no definido. |
| POWER LIGHT .....                                   | ¡Error! Marcador no definido. |
| OUTSIDE TEMPERATURE .....                           | ¡Error! Marcador no definido. |
| CURRENT TIME .....                                  | ¡Error! Marcador no definido. |
| BLUETOOTH CONNECTION .....                          | ¡Error! Marcador no definido. |
| DRIVING MODE .....                                  | ¡Error! Marcador no definido. |
| ESTIMATED BATTERY RANGE .....                       | ¡Error! Marcador no definido. |
| SPEEDOMETER .....                                   | ¡Error! Marcador no definido. |
| SERVICE .....                                       | ¡Error! Marcador no definido. |
| ODO .....   | ¡Error! Marcador no definido. |
| TEMP .....  | ¡Error! Marcador no definido. |
| TRIP1 .....   | ¡Error! Marcador no definido. |
| TRIP2 .....   | ¡Error! Marcador no definido. |
| b) Buttons .....                                    | ¡Error! Marcador no definido. |
| SWITCHING BETWEEN SCREENS .....                     | ¡Error! Marcador no definido. |
| CHANGE VIEW KMS PARTIAL - AVERAGE SPEED (AVG) ..... | ¡Error! Marcador no definido. |
| RESET PARTIAL KMS .....                             | ¡Error! Marcador no definido. |
| CHANGE TEMPERATURE VIEW .....                       | ¡Error! Marcador no definido. |

|   |                               |
|---|-------------------------------|
| CHANGE TIME .....                                     | ¡Error! Marcador no definido. |
| CHANGE UNIT MEASUREMENTS .....                        | ¡Error! Marcador no definido. |
| GET RID OF SPANNER ICON FOR SERVICE/REVISION.....     | ¡Error! Marcador no definido. |
| c) Warning lights .....                               | ¡Error! Marcador no definido. |
| <b>4) Vehicle controls and driving.....</b>           | ¡Error! Marcador no definido. |
| d) Controls on the left side of the handlebar .....   | ¡Error! Marcador no definido. |
| Lamps:.....   | ¡Error! Marcador no definido. |
| Indicators. ....                                      | ¡Error! Marcador no definido. |
| Horn. ....  | ¡Error! Marcador no definido. |
| Reverse lamps. ....                                   | ¡Error! Marcador no definido. |
| e) Combined brake and regenerative brake .....        | ¡Error! Marcador no definido. |
| f) Controls on the right side of the handlebar .....  | ¡Error! Marcador no definido. |
| Accelerator .....                                     | ¡Error! Marcador no definido. |
| Hazard/low beams .....                                | ¡Error! Marcador no definido. |
| INFO .....  | ¡Error! Marcador no definido. |
| MODE .....  | ¡Error! Marcador no definido. |
| g) Ignition .....                                     | ¡Error! Marcador no definido. |
| BLOCK HANDLEBAR.....                                  | ¡Error! Marcador no definido. |
| OPEN SEAT .....                                       | ¡Error! Marcador no definido. |
| SHUT OFF /UNBLOCK HANDLEBAR.....                      | ¡Error! Marcador no definido. |
| IGNITION .....  | ¡Error! Marcador no definido. |
| <b>5) Lighting .....</b>                              | ¡Error! Marcador no definido. |
| h) Front lamp .....                                   | ¡Error! Marcador no definido. |
| i) Front sidelights - indicator lights .....          | ¡Error! Marcador no definido. |
| j) Rear lights.....                                   | ¡Error! Marcador no definido. |
| <b>6) Seat – compartment inside seat.....</b>         | ¡Error! Marcador no definido. |
| k) Open and close seat .....                          | ¡Error! Marcador no definido. |
| l) Remove battery .....                               | ¡Error! Marcador no definido. |
| m) Fuse box .....                                     | ¡Error! Marcador no definido. |
| <b>7) Stands.....</b>                                 | ¡Error! Marcador no definido. |
| n) Side stand .....                                   | ¡Error! Marcador no definido. |
| o) Centre stand .....                                 | ¡Error! Marcador no definido. |
| <b>8) Rear-view mirrors .....</b>                     | ¡Error! Marcador no definido. |
| <b>C. MOBILE APP - SCOOTER ALWAYS CONNECTED .....</b> | ¡ERROR! MARCADOR NO DEFINIDO. |
| <b>D. ACCESSORY COMPONENTS.....</b>                   | ¡ERROR! MARCADOR NO DEFINIDO. |

|   |                               |
|---|-------------------------------|
| 1) <b>Battery Pack Components</b> .....                             | ¡Error! Marcador no definido. |
| a) Trolley removable battery system.....                            | ¡Error! Marcador no definido. |
| b) Internal charger.....  | ¡Error! Marcador no definido. |
| c) Light ring.....  | ¡Error! Marcador no definido. |
| 2) <b>Power</b> .....   | ¡Error! Marcador no definido. |
| 3) <b>Battery sharing (Available soon)</b> .....                    | ¡Error! Marcador no definido. |
| 4) <b>Battery monitoring system (BMS)</b> .....                     | ¡Error! Marcador no definido. |
| 5) <b>Connecting charging unit</b> .....                            | ¡Error! Marcador no definido. |
| a) First aid.....   | ¡Error! Marcador no definido. |
| b) Fire protection.....   | ¡Error! Marcador no definido. |
| 1) <b>Charge level</b> .....  | ¡Error! Marcador no definido. |
| 2) <b>Lights and indicators</b> .....                               | ¡Error! Marcador no definido. |
| 3) <b>Stands</b> .....  | ¡Error! Marcador no definido. |
| 4) <b>Tyres</b> .....   | ¡Error! Marcador no definido. |
| Rear tyre.....  | ¡Error! Marcador no definido. |
| 5) <b>Brakes</b> .....  | ¡Error! Marcador no definido. |
| a) Brake fluid .....  | ¡Error! Marcador no definido. |
| b) Front brake.....   | ¡Error! Marcador no definido. |
| c) Rear brake .....   | ¡Error! Marcador no definido. |
| d) Brake lever.....   | ¡Error! Marcador no definido. |
| C. SOLVING PROBLEMS.....  | ¡Error! Marcador no definido. |
| <b>E. CLEANING AND STORAGE (GUIDE TO PARKING THE VEHICLE)</b> ..... | ¡Error! Marcador no definido. |
| 1) <b>Cleaning</b> .....  | ¡Error! Marcador no definido. |
| 2) <b>Storage</b> .....   | ¡Error! Marcador no definido. |
| <b>A. DELIVERY TO BUYER</b> .....                                   | ¡Error! Marcador no definido. |
| <b>B. WARRANTY CONDITIONS</b> .....                                 | ¡Error! Marcador no definido. |
| <b>(GROUNDS FOR VOIDING WARRANTY)</b> .....                         | ¡Error! Marcador no definido. |
| <b>C. INSPECTIONS: SCOOTER &amp; BATTERY</b> .....                  | ¡Error! Marcador no definido. |
| Registry of inspections S01 (both scooter and battery): .....       | ¡Error! Marcador no definido. |

# 1. GENERAL CHARACTERISTICS AND OPERATING THE VEHICLE

## A. VEHICLE IDENTIFICATION

### 1) VIN Number - chassis number

The VIN number is an alphanumeric code with 17 digits that identifies your scooter. The VIN number is established according to ISO standards. **The VIN number must be given when ordering replacement parts.**

The VIN number is engraved directly on the chassis of the scooter, on the square bar on the rear right (see picture).

### 2) Information tag - production plate

This scooter has a tag with the chassis number, maximum allowable noise, maximum mass and revolutions per minute.

The tag is on the rear left, on the opposite side from the number engraved on the chassis (see picture).



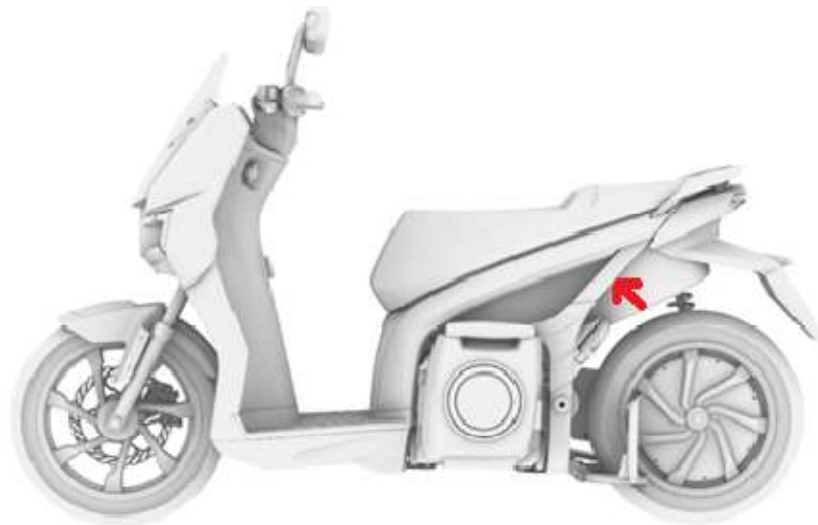

|                       |                             |
|-----------------------|-----------------------------|
| SCUTUM LOGISTIC, S.L. |                             |
| L3e - A1              |                             |
| ○                     | e9*168/2013*11421 ○         |
| ○                     | UCYS01300JB000001 ○         |
| ○                     | dB(A) - min <sup>-1</sup> ○ |
|                       | max 320 Kg                  |
| TYPE: S01A            |                             |

## B. BASIC COMPONENTS

The basic components (from a user standpoint) that make up the scooter are:



## 1) Battery pack (*be*)

The SILENCE S01 model has an innovative removable battery pack with a handle and wheels so it can be transported like a trolley. This way, you can charge it on the scooter or wherever you want, taking the battery to a power source. Plus, this battery pack can be used on other scooters, or even used to power other devices.

For more information, see the section of this manual on the battery pack, which explains all the specifications and how to use your new battery.

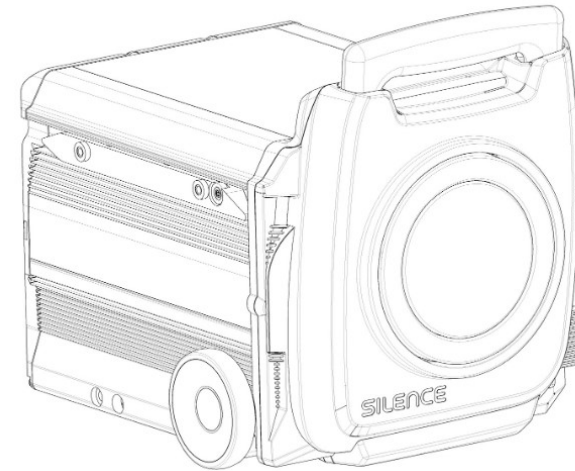

## 2) Motor (rear wheel)

On the rear wheel, this scooter has a 100% electric motor with brushless technology (HUB), direct transmission and an air cooling system.

The nominal power is 7,000 W (L3e homologation) and it has a maximum speed of 100 kilometres per hour. For L1e homologation, the nominal power and speed are limited electronically to 4,000 W and 45 km/h, respectively.

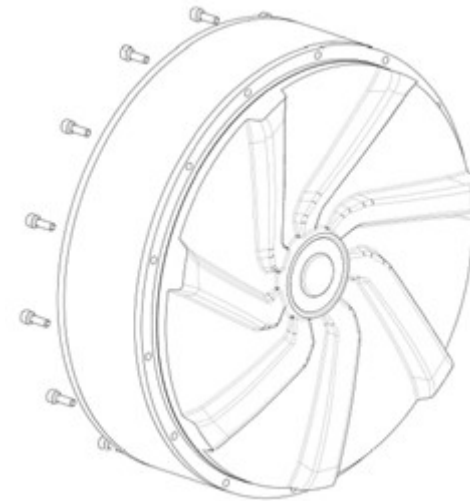

### 3) Instrument panel

The instrument panel gives you all the information you need to know about the scooter while driving.

It features an LCD screen, 2 buttons (“SET” and “INFO”) and 10 warning lights, which are explained below.

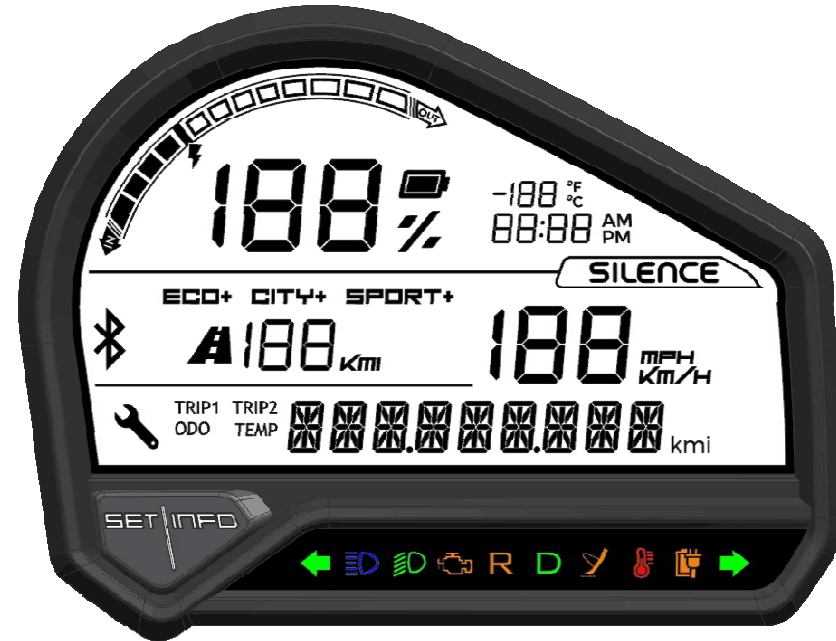



a) LCD screen

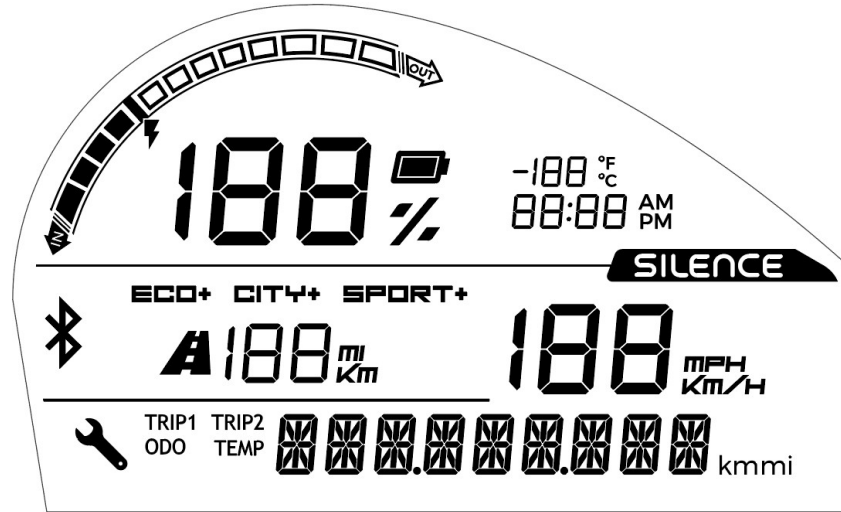

**CHARGE GAUGE**

On the bottom of the screen, there is an SoC gauge (State of Charge). This is shown as a percentage, so when the battery is completely drained it will read 0% and when it is fully charged it will show 100%.

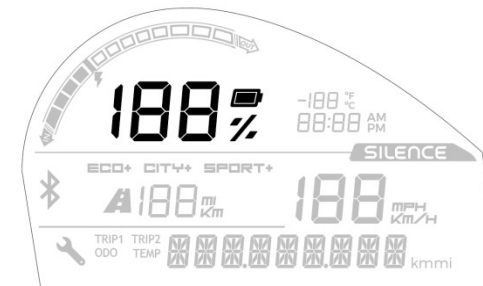

## POWER LIGHT

Plus, on the upper left, there is a light that shows whether power is flowing out of the battery (being used) or into it (regenerated through the brake motor or charging).

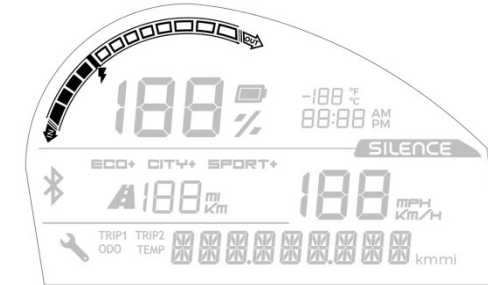

## OUTSIDE TEMPERATURE

On the top right, there is a temperature gauge (showing the outside temperature in Celsius or Fahrenheit, depending on the settings). It shows both positive and negative temperatures.

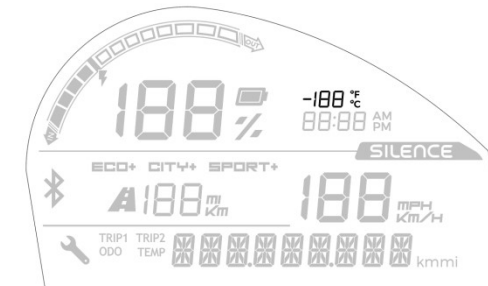

## CURRENT TIME

Just below that, there is a clock showing the current time (battery data). The time can be shown using the 12-hour or 24-hour clock systems.

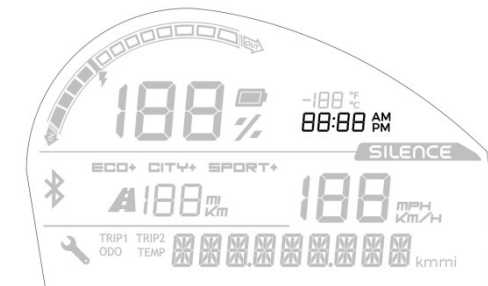

## BLUETOOTH CONNECTION

This icon shows that the scooter ECU is paired with the driver's smartphone. It blinks when pairing and stays on once the connection has been made. The light turns off when the user disconnects their smartphone.

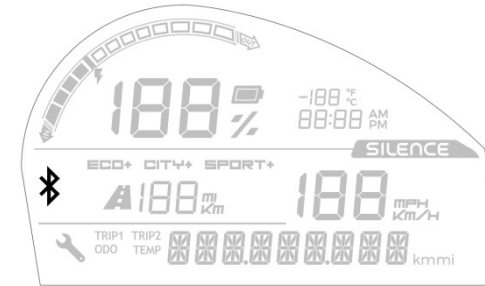

## DRIVING MODE

On the top middle (below the charge percentage), the screen shows the current driving mode (ECO, CITY or SPORT).

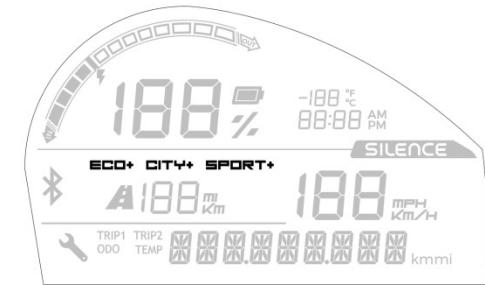

## ESTIMATED BATTERY RANGE

Below the driving modes, there is information about the remaining range, in kilometres or miles. This is approximate and depends on driving style and current use of power.

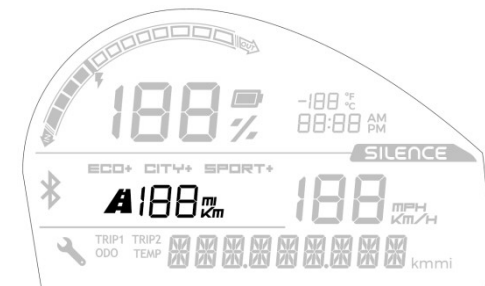

## SPEEDOMETER

In the middle on the right (under the SILENCE logo), a gauge shows the scooter's current speed. It can be set to kilometres per hour or miles per hour.

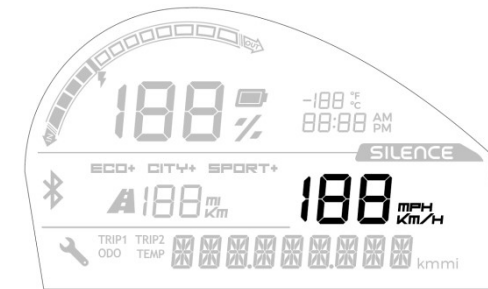

## SERVICE

When it is time for a scheduled service (determined by the number of kilometres travelled), a spanner icon will appear in the lower left corner.

After the scooter has been serviced, the authorised SILENCE mechanic will deactivate the icon and it will not appear again until it is time for another scheduled service. The icon is just a reminder and getting rid of it does not constitute certification of having passed a revision. To get rid of the icon, the scooter must be turned off and you press the SET and INFO buttons at the same time and start the scooter (while holding the buttons down).

Regardless of the kilometres travelled, the scooter must pass at least one revision yearly if it hasn't reached the kilometres to trigger the spanner icon.

Please read the maintenance section of the manual for more information.

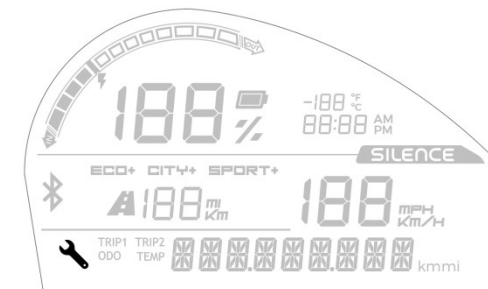

## ODO

Odometer: Indicates the total kilometres/miles travelled.

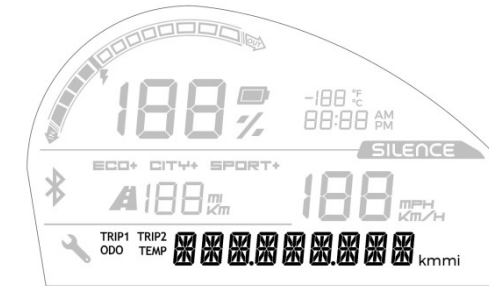

1 click on INFO to show:

## TEMP

Temperature of various parts, in Celsius or Fahrenheit.

Holding down the INFO button you can get:

- TEMP BAT: Temperature of the battery pack.
- TEMP ENG: Temperature of the engine.
- TEMP INV: Temperature of the inverter.

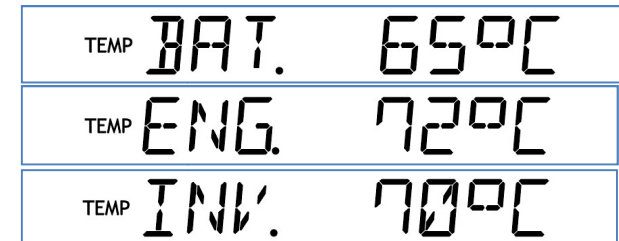

1 click on INFO to show:

## TRIP1

Partial odometer 1: Shows the kilometres/miles travelled since the last time it was reset.

Holding down the INFO button you can get:

- KM/MI: Kilometres/miles travelled.
- AVG: Average speed for these kilometres/miles (in km/h or mi/h).

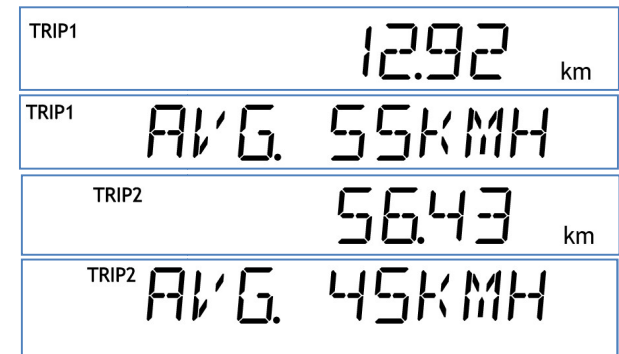

1 click on INFO to show:

## TRIP2

Exactly the same as TRIP1. 1 click on INFO to show ODO again.

## b) Buttons

The buttons on the instrument panel are **INFO** (right, and the same on the controls on the right side of the handlebar) and **SET** (left):



They are used for:

### **SWITCHING BETWEEN SCREENS**

**Single click on INFO:** takes you through the following screens with each click, in this order: ODO, TEMP, TRIP1, TRIP2.

### **CHANGE VIEW KMS PARTIAL - AVERAGE SPEED (AVG)**

In TRIP1 or TRIP2, **hold down INFO**.

### **RESET PARTIAL KMS**

In TRIP1 or TRIP2, **single click on INFO**. The kilometre count will be reset.

### **CHANGE TEMPERATURE VIEW**

In TEMP, hold down **INFO**: go through screens TEMP BAT, TEMP ENG and TEMP INV.

## CHANGE TIME

**Hold down SET:** go into time change mode.

**Single click SET:** change hours, minutes and time mode (they will start blinking).

When the hour is blinking, **single click INFO:** increase hours by one unit. **Hold down INFO:** hour will increase quickly.

When the minutes are blinking, **single click INFO:** increase minutes by one unit. **Hold down INFO:** minutes will increase quickly.

When the time mode is blinking, **single click INFO:** change between am/pm and 24-hour mode.

**Hold down SET:** set time and exit time change mode.

## CHANGE UNIT MEASUREMENTS











**Hold SET (while starting scooter):** change between metric system (°C, km/h, km) and Imperial measurements (°F, mph, mi).

## GET RID OF SPANNER ICON FOR SERVICE/REVISION

**Hold down SET and INFO at the same time (while starting scooter):** the service spanner icon (revision reminder) will disappear until the next scheduled service is required.

c) Warning lights



|   |  |
|---|--|
|    | Left indicator light.  |
|    | High-beams light   |
|    | Low-beams light  |
|    | OBD light. Comes on when there is an issue. If it disappears, the light should go off after you start the scooter 3 times.   |
|    | Reverse-gear light.  |
|    | Gear light. This comes on when the scooter has done all the necessary checks and is ready to drive.  |
|   | Side stand (or kickstand) light. This comes on when the stand is out. The engine is also blocked automatically so the scooter won't move with the stand out.   |
|  | Temperature light This blinks if any part is near its maximum allowable temperature. It stays on without blinking when it is over the maximum temperature. Motor: 100°C (blinking), 110°C (steady). Controller: 70°C (blinking), 75°C (steady). BMS: 50°C (bl.), 65°C (st.) / -10°C (bl.), -15°C (st.) |
|  | Charge gauge. Steady when connected to a power source.   |
|  | Right indicator light.   |



## 4) Vehicle controls and driving

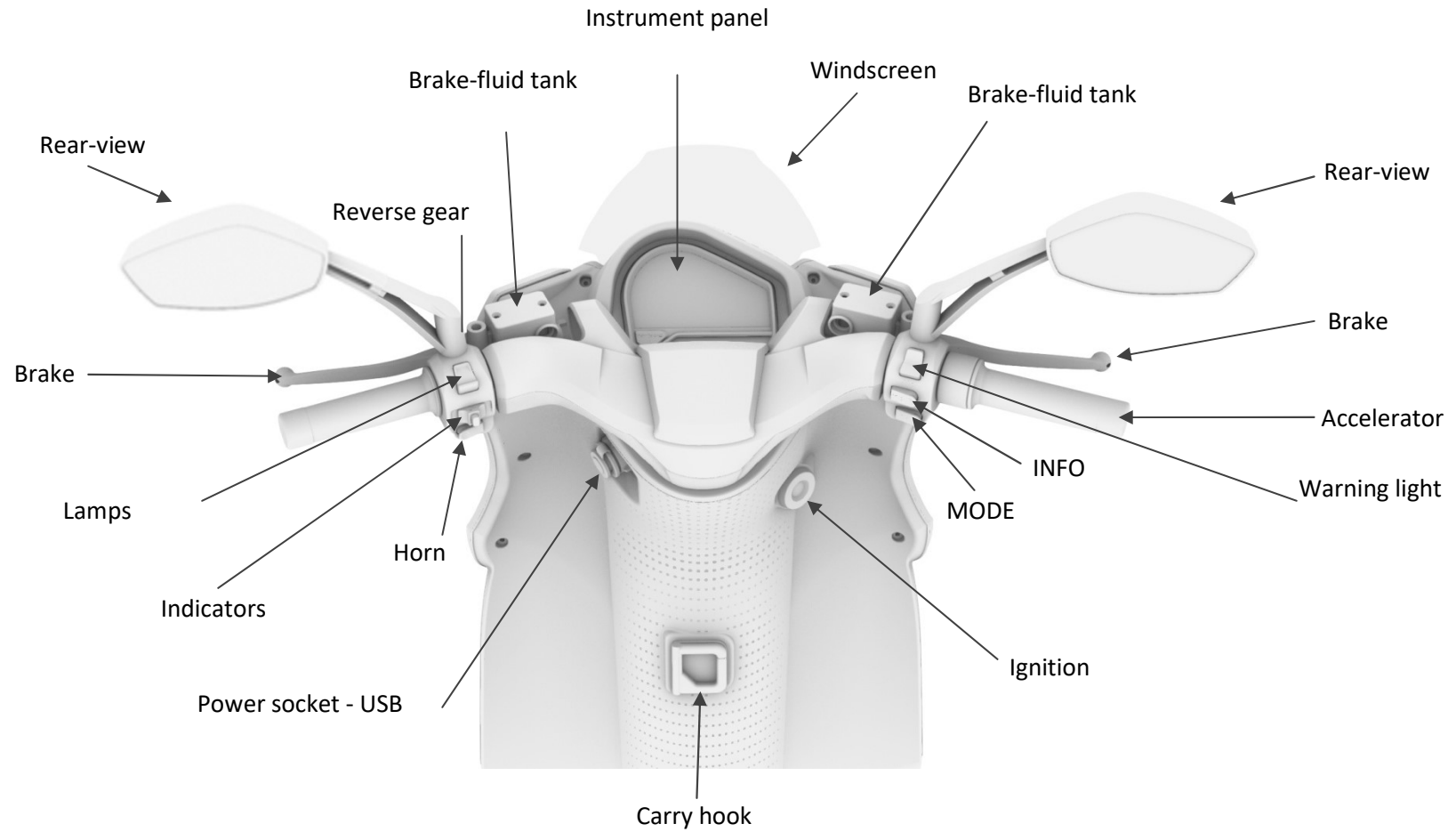

d) Controls on the left side of the handlebar



**Lamps:**

- **Position 1** (lever -> press down, return to rest position): BURSTS. Allows you to flash your high beams to warn other drivers on the road.
- **Position 2** (lever -> leave in position 2): **HIGH BEAMS**  
To switch on the high beams, hold down the lever on the top.

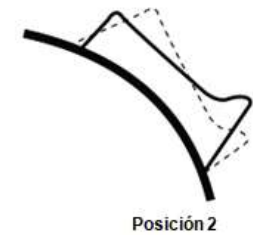
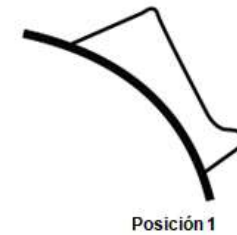

When the high beams are on, the blue light below will come on in the instrument panel:



## Indicators.

To use the indicators, press the lever to the right to indicate you are turning right and to the left, when turning left. Press the central **white** button to reset the position and turn indicators off.

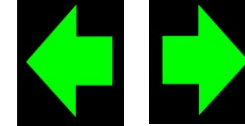

## Horn.

Press the button **with the horn symbol** to honk the horn.



## Reverse lamps.

This scooter has a reverse gear. To use this function, press the **green button** on the back of the left brake lever and accelerate gently while holding it down. The following warning light will come on in the instrument panel.



Use it carefully, especially the first time. This helps manoeuvre for parking or to get out of a parking spot in reverse.

### e) Combined brake and regenerative brake

This scooter is equipped with a combined brake system that works as follows:

The right brake lever activates a mechanical break on the front wheel (disc brake) and the regenerative brake (electronic) on the rear wheel. The left brake lever activates a mechanical break on both the front and rear wheels (both disc brakes through the brake distributor).

Both levers are adjustable.

The first part of the front brake lever activates only the regenerative brake, so it can be used without activating the mechanical brake (front disc brake). Then both brakes are activated together. Using the regenerative brake helps braking while maintaining battery charge.

How to brake with the regenerative brake:

- At first, as you squeeze the front brake lever (right), it activates the regenerative brake. This system brakes the rear wheel electronically and regenerates energy in the battery.

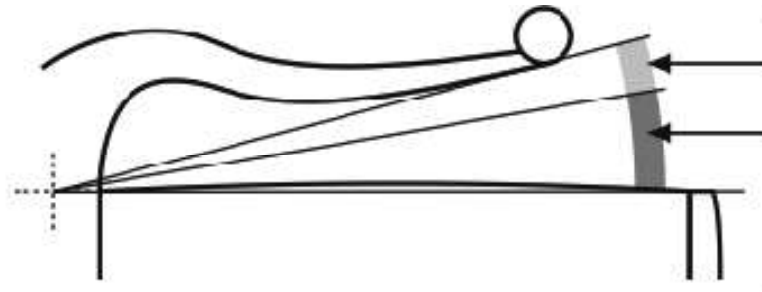

- If you keep squeezing the brake lever, it will also activate the mechanical brake on the front wheel. The more pressure you put on the lever, the more the mechanical brake will be used.

The regenerative brake applied depends on the driving mode selected (see “¡Error! No se encuentra el origen de la referencia.”).

f) Controls on the right side of the handlebar



**Accelerator**

To speed up, twist the accelerator down. To go back to the neutral position, let it go.

**Hazard/low beams**

- **Position 1** (lever -> press down, return to rest position): **LOW BEAMS**. Allows you to switch on and off your low beams. When the low beams are on, the green light below will come on in the instrument panel:
- **Position 2** (lever -> press down, return to rest position): **HAZARDS**. Switches on and off the indicator lights on both sides at the same time:



You can switch on your hazard lights and leave them on even after taking the key out of the scooter. To do so, switch them on with the key in and then remove it. After they have been switched off, they can't be switched on again without putting the key back in.

## INFO

This button is the same as the INFO button on the speedometer and has the same functions (see “¡Error! No se encuentra el origen de la referencia.” section).

## MODE

This button has two uses:

- **Starting the scooter:** after you start the vehicle with the key or the APP, press the **MODE** button until the green “D” lights up on the instrument panel and you hear a chime. Plus, the front sidelights will switch on (the rear sidelights go on automatically when you turn the key to ON).
- **Mode selector:** this scooter has three different driving modes, which can be chosen using the **MODE** button.



These are:

- **CITY “C”:** The scooter has been designed to drive regularly in CITY “C” mode. This gives the vehicle good performance and balanced consumption. This is the default mode when you switch on the scooter. It includes limited use of the regenerative brake.
- **SPORT “S”:** This driving mode gives you more power and speed at specific moments. Frequent use of the SPORT mode decreases the scooter’s range (kilometres it can travel with a full charge) as it uses more power and can raise the temperature of the engine/battery, which could have a negative effect on performance or cause the scooter to shut off. The full regenerative brake is used.

- **ECO “E”**: This mode is for more relaxed driving, with limited speed and acceleration. It gives the vehicle a longer range. It does not use the regenerative brake.

The top speed for each mode is:

|              | Top speed (km/h) |
|--------------|------------------|
| <b>ECO</b>   | <b>67</b>        |
| <b>CITY</b>  | <b>85</b>        |
| <b>SPORT</b> | <b>100</b>       |

**SPORT mode is only available when the following conditions are met:**

|                     |                       |                        |                       |
|---------------------|-----------------------|------------------------|-----------------------|
| <b>SoC &gt; 20%</b> | <b>Tbat &lt; 45°C</b> | <b>Tmot &lt; 105°C</b> | <b>Tinv &lt; 70°C</b> |
|---------------------|-----------------------|------------------------|-----------------------|

...SoC means the State of Charge for the battery and T means temperature of the battery, motor and inverter, respectively.

The current driving mode is shown on the instrument panel. Single click to switch between ECO, CITY and SPORT modes in the following order: **C-S-C-E-C-S-C-...**

When switching between modes, the name of the next mode will flash on screen for a few seconds and will stop flashing when it is chosen. This way, you can jump 3 modes without having to activate the next mode in the sequence.

**You can go straight from SPORT to CITY. To go from any mode to ECO, however, you have to be driving under 55 km/h.** For safety reasons, power will be limited in any of the following cases:

|                    |                     |                    |
|--------------------|---------------------|--------------------|
| <b>Tbat ≥ 45°C</b> | <b>Tmot ≥ 110°C</b> | <b>Tinv ≥ 70°C</b> |
|--------------------|---------------------|--------------------|

If the battery temperature is above **60°C**, it stops powering the motor and the scooter will shut off to protect itself (the power will decrease gradually before reaching this point).

### g) Ignition

Positions:

#### **BLOCK HANDLEBAR**



Turn the handlebar all the way to the left. Put the key in, push in and turn left.

Now all the functions are blocked and the scooter movements are highly limited:



#### **OPEN SEAT**

Turn the key to the left to block the handlebar but don't push it in. The seat lock will release. To close it, press down on the rear of the seat until you hear the lock click. You can also open it by pressing both brake levers at the same time with the side stand out.

#### **SHUT OFF /UNBLOCK HANDLEBAR**



All the functions are blocked but the handlebar isn't blocked (the scooter can be moved). You can work on the scooter safely.

#### **IGNITION**



All functions are ready to be used. The scooter is ready to be driven if you hold in the MODE button until READY appears on the speedometer and the green drive light (D) comes on. In this position, the key can't be removed.

The scooter can also be started with our APP, which means you can share it without having to share the physical key.



## 5) Lighting

All of the lighting on this scooter is based on LED technology, including indicators, sidelights, brake lights, high and low beams. There are no lightbulbs to change.

The various lighting groups are:

### h) Front lamp

Includes high and low beams, and front sidelights.

### i) Front sidelights - indicator lights

On either side of the front lamp, there is an LED group used for the front sidelights and indicator lights.

### j) Rear lights

On the back of the scooter, there are rear sidelights, brake lights and rear indicator lights.



Front lamp

Front  
sidelights



Rear lights

## 6) Seat – compartment inside seat

### k) Open and close seat

The seat of your SILENCE S01 has room for the driver and one passenger, plus a large compartment inside with enough space for 2 helmets.



There are three ways to open this compartment:

- With the key. Put the key into the ignition, turn left and then lift up the seat (as indicated in the “Ignition” sub-section).
- With the APP.
- Manually. By pressing both brake levers at the same time with the side stand out.

The following elements are found inside the compartment:



To lock the seat, push it down until the latch clicks.  
driving.



Battery release latch:



Fuse box and OBD connector (diagnosis):

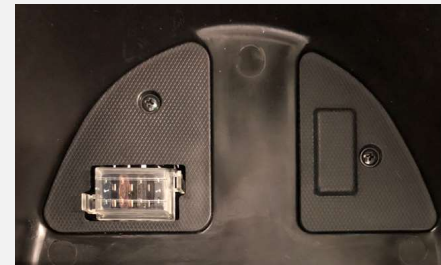

before

Power socket to charge the battery on the scooter:



I) Remove battery

To remove the battery pack easily in just seconds, follow these steps (with the scooter on the centre stand):



Open the seat with the APP, with the key, or pressing both brake levers



Pull the lever



Extract the Battery Pack



Transport the Battery Pack



Plug it to any Schuko socket



Once charged, unplug it



Transport and enter the Battery Pack in the scooter



Make sure that the battery is properly locked

**IMPORTANT:** Never remove or put back the battery pack when the scooter is charging or with the key in the ignition. Make sure **not to flip out the handle before pulling the pack out** (flip it out after the battery has been removed from the scooter).

The wheels and base of the pack slide out and fold up automatically when you remove it or put it back in the scooter. **Nevertheless, it is your responsibility to do this slowly and make sure the wheels and base come out properly, and that when putting it back in, it is properly anchored** (check before driving).

Whenever the battery is not in the scooter, the (*Multicontact*) cord on the scooter must be covered with the rubber cap designed for this purpose. The goal is to protect it while the battery is out:

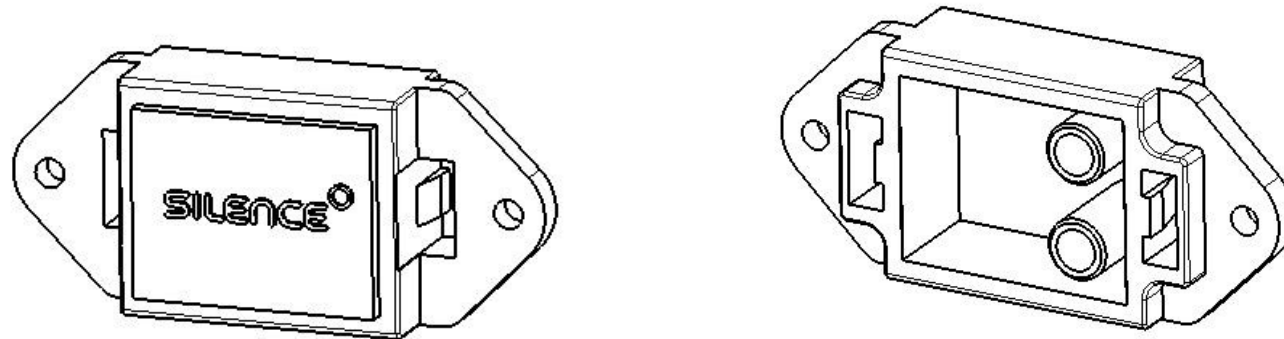

**WARNING: don't put the protective cap on while the scooter is plugged in and never get the cord wet (even with the cap on).**

### m) Fuse box

The fuse box is located under a protective lid, inside the seat compartment:



The scooter has 4 fuses, from left to right (from the driver's point of view):

- F1 (Black): 1A fuse protecting the USB port
- F2 (Orange): 5A fuse protecting the 12V power source
- F3 (Grey): 2A fuse protecting the 60V power source
- F4 (Black): 2A fuse protecting the SEVCON

## 7) Stands

### n) Side stand

The side stand is on the left side of the scooter.  
To put down the side stand, push the “U” shaped leg down.  
The side stand should be used when the ground is too unstable or on a slight incline, making it impossible to use the centre stand.



### o) Centre stand

The centre stand is on the bottom of the scooter.  
This stand supports the scooter in a vertical position.  
To put the scooter on this stand, push the leg down with your foot as you push or pull the scooter gently up or down.  
The centre stand should be used when the ground is stable or flat, and for long parking periods or servicing.



## 8) Rear-view mirrors

Before driving, always make sure both mirrors are properly adjusted to the current driver.



## C. MOBILE APP - SCOOTER ALWAYS CONNECTED

If one thing sets the S01 apart, it is its mobile app. It lets you stay connected no matter where you are, and lets you safely share your scooter with anyone you want. It is the first electric scooter that comes standard with this connection and was designed from the very beginning to have this function. The whole system is designed by and for users, making it easier to use the scooter and providing all the information you need in a fully personalised way.

Using the “**SILENCE Connected**” APP, you can:

- KEEP AN EYE ON YOUR VEHICLE AT ALL TIMES

Switch your SILENCE on and off, open the seat. Share with whoever you want, using a code, without having to be there physically or give them your key.

- FIND YOUR SCOOTER

With the app, you’ll know where your scooter is all the time, using geolocation.

- KNOW YOUR BATTERY STATUS

You can check the battery level and remaining range in CITY mode, whenever you want.

- SAFE AND CALM

You’ll get warnings on the temperature of the vehicle and its main parts.

- PLAN YOUR ROUTE

Put your destination into the app and it will create the best route, giving you information on estimated time and kilometres, to make sure the battery charge is optimal to get you where you’re going.

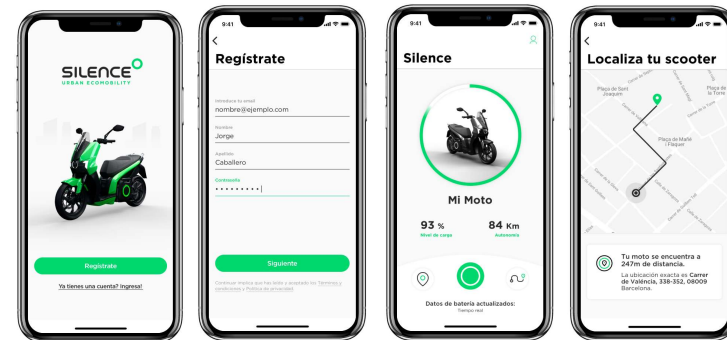

- FALL AND THEFT WARNING

You’ll get warnings if your vehicle is moved without your authorisation or knocked over.

- FIND OUT YOUR CARBON FOOTPRINT

You’ll get statistics on the CO2 saved on each of your journeys.

The APP, available for iOS and Android, was developed to be totally intuitive and self-explanatory. For more information (and for the most up-to-date info) on the APP, go to <https://www.SILENCE.eco/conectividad/>.



## D. ACCESSORY COMPONENTS

### SILENCE rear storage box

The S01 has an optional rear piece with grab handles/rack for rear storage boxes, which replaces the standard grab handles.



### Screen



### Inverter

The S01 battery, in addition to powering the scooter, can also be used to power other domestic devices with the SILENCE inverter (700W):

For more information, see the "BATTERY AND CHARGER SPECIFICATIONS" section.



### Smartphone Dock



## 2. SCOOTER, BATTERY AND CHARGER SPECIFICATIONS

### A. SCOOTER SPECIFICATIONS (Scooter part + motor)

| SCOOTER                           |                            |     |
|-----------------------------------|----------------------------|-----|
| CHASSIS                           |                            |     |
| Construction                      | Steel tubes                |     |
| MAIN MEASUREMENTS                 |                            |     |
| Total length                      | 2,040                      | mm  |
| Total width                       | 710                        | mm  |
| Total height                      | 1,115                      | mm  |
| Wheelbase                         | 1,420                      | mm  |
| Seat height                       | 790                        | mm  |
| MASSES                            |                            |     |
| MAM: Maximum Authorised Mass      | 320                        | kg  |
| MAM front axle                    | 102                        | kg  |
| MAM rear axle                     | 218                        | kg  |
| Weight of vehicle with battery    | 146                        | kg  |
| Weight of vehicle without battery | 110                        | kg  |
| Battery weight                    | 36                         | kg  |
| FRONT WHEEL ASSEMBLY              |                            |     |
| FRONT WHEEL                       |                            |     |
| Front rim                         | 15"                        |     |
| Front tyre                        | 120/70-15                  |     |
| Pressure front tyre               | 1.8 – 2.0                  | bar |
| FRONT BRAKE                       |                            |     |
| Type                              | Disc (hydraulic, combined) |     |
| Diameter                          | 260                        | mm  |

| FRONT SUSPENSIONS            |   |       |
|------------------------------|---|-------|
| Type                         | Conventional hydraulic telescopic fork                                      |       |
| Travel                       | 80  | mm    |
| REAR WHEEL ASSEMBLY          |   |       |
| REAR WHEEL                   |   |       |
| Rear rim                     | 14"   |       |
| Rear tyre                    | 140/70-14   |       |
| Pressure rear tyre           | 2.3 - 2.5   | bar   |
| REAR BRAKE                   |   |       |
| Type                         | Disc (hydraulic, combined) + Regenerative                                   |       |
| Diameter                     | 240   | mm    |
| REAR SUSPENSION              |   |       |
| Type                         | Single side shock absorber  |       |
| Travel                       | 100   | mm    |
| POWERTRAIN                   |   |       |
| MOTOR                        |   |       |
| Type                         | Brushless, on the wheel. Reversible: regenerative motor brake. Reverse gear |       |
| Nominal power                | 7   | kW    |
| Peak power                   | 9   | kW    |
| Maximum speed of the vehicle | 100   | km/h  |
| Ratio power/mass             | 0.063   | -     |
| ENERGY EFFICIENCY            |   |       |
| Energy consumption           | 58.54   | Wh/km |
| Environmental regulations    | Euro 4  | -     |
| Range (BP 5 kWh)             | 115   | km    |

## B. BATTERY AND CHARGER SPECIFICATIONS

### DISCLAIMER

The battery can be a **VERY DANGEROUS** product (life threatening) when not on the scooter:

- It should always be moved on its wheels, slowly (max. 3 km/h), slower than the average person walks.
- Avoid mistreating the battery, including hitting or bouncing it, rolling it over cobblestones, stairs or holes, or dropping it (down stairs, for example), as this could cause it to catch fire. Avoid all contact with water.
- If there is any indication or you suspect the Battery Pack has been used improperly or fallen, don't plug it in. Call a SILENCE Official Service Centre (SVD), as this could be **LIFE THREATENING**.

A battery fire can be put out with water or CO<sub>2</sub>, unless the battery is plugged in or near other batteries. In this case, use a CO<sub>2</sub> extinguisher to put out the fire and take it to a safer, more isolated location (at least 15m from any exposure: other vehicles, batteries, etc.). Once in a secure location, call emergency services to take control of the situation.

| BATTERY SPECIFICATIONS         |   |             |              |
|--------------------------------|---|-------------|--------------|
| Nominal charge                 | 5kWh  |             |              |
| Chemistry of the cells         | Lithium-ion cells                             |             |              |
| Weight                         | 36kg  |             |              |
| Height unfolded                | 870mm   |             |              |
| Housing height                 | 270mm   |             |              |
| Wheel width                    | 330mm   |             |              |
| Housing depth                  | 440mm   |             |              |
| Nominal voltage of the battery | 51VDC   |             |              |
| Storage temperature            | -20 to 45°C max.<br>-20 to 25°C recommended   |             |              |
| Operating temperature          | 0°C to 45°C (charging)<br>-20°C to 60°C (use) |             |              |
| Housing material               | Aluminium and PA66                            |             |              |
| Maximum charge power           | 35A   |             |              |
| Maximum discharge power        | 250A  |             |              |
| Charger type                   | Onboard 90-240VAC; 600W                       |             |              |
| Standard charge time           | 6-8h  |             |              |
| Modes                          | <b>Eco</b>                                    | <b>City</b> | <b>Sport</b> |
| Maximum driving distance       | 115km   | 108km       | 70km         |

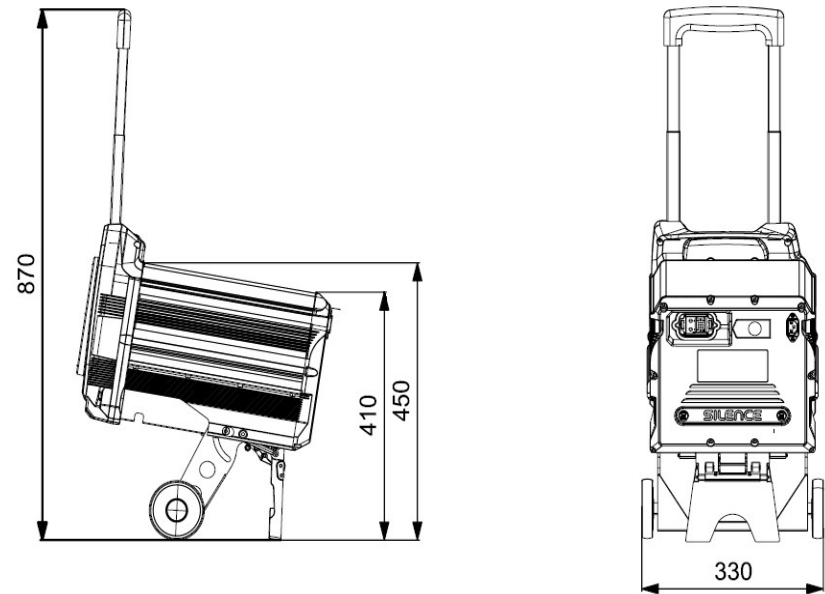

## 1) Battery Pack Components

The SILENCE S01 model has an innovative removable battery pack that, in addition to its basic internal systems, also has the following elements:

### a) Trolley removable battery system

This system includes an extendible handle, two wheels and a support base (to use on flat, horizontal surfaces). To learn more about how to remove it from the scooter, see the “¡Error! No se encuentra el origen de la referencia.” section.



### b) Internal charger

Integrated into one of the side covers, the internal 600W charger allows the battery to be charged on the scooter or on its own, using the conventional plug (Schuko) with a cable adapter Schuko-IEC:

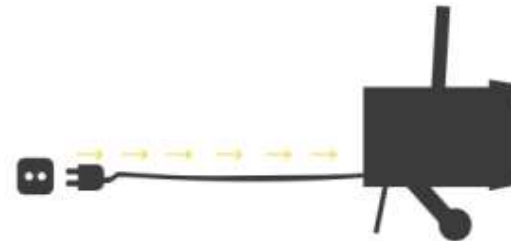

Information on the battery charge level is available whether or not the battery is in the scooter, on an LED light ring on one side of the battery pack. Just touch the inside of the ring lightly for the following information:



**NOT CHARGING:** when you touch the centre of the ring, it will show red and blue light trails, each moving around the ring in opposite directions. Then it will be shown in turquoise, and then the remaining charge will be indicated as a portion of the ring lit up in green (or the whole ring if the battery is 100% charged). When the battery charge is low, the current charge will be shown in red.

**CHARGING:** while the battery is charging, a green light trail moving around the ring will alternate with a portion of the ring lit up, showing the percentage of the battery charged. When it reaches 100%, the ring will be all green with a blue light trail moving around the ring while it is plugged in.

If the scooter ignition is on, the ring won't light up under any circumstances.

## 2) Power

With our removable battery system on the S01 model, we've created a series of pieces to give our batteries additional uses. It's not just about getting around the city on your electric scooter and being able to charge it wherever you want, whenever you want. Now you can also use it to power many other devices.



- **Energy IN:** On the one hand, you'll find the power to charge the battery pack, which at SILENCE we call "Energy IN". You can charge your battery with one of our quick charging cabinets, plug it directly into a normal socket, or use solar power. At SILENCE we've developed a solar tree (*Solar be Tree*) that can be purchased as an accessory, to generate a clean power circle.



- **Energy OUT:** On the other hand, we have “**Energy OUT**”, which is everything that can be powered using the battery, meaning all the applications for the battery pack: power for your S01, or your computer, television, camping stove, coffee maker or microwave, for example.

Anything that needs electric power can be plugged into the **inverter** SILENCE has developed to adapt the voltage to 700W and power everything you use. Just connect the *Battery Pack* to the *inverter*, which changes 60V to 220V power. It has 2 power points where you can plug in any electronic device or appliance, wherever you are.



### 3) Battery sharing (Available soon)

Soon you'll be able to use the SILENCE Battery Stations to share batteries. You can book a fully charged battery through the SILENCE APP and exchange it for your dead battery, without having to wait to charge. *Only for purchase with battery hire.*



#### 4) Battery monitoring system (BMS)

This battery has a monitoring system, called the **BMS (Battery Management System)**, that controls things like temperature and voltage. It was developed by the SILENCE R&D team and plays a very important role in balancing the individual charge of each cell and the overall charge of each series of cells, making sure the battery works at an optimal level.

This system also provides information on the charge level and sets protocols for charging and discharging power. Additionally, it includes an action plan for irregular battery status, triggering preventive measures in case of power, voltage or temperature spikes, etc.

In short, the BMS is the battery's "brain", ensuring optimal performance and safety.

#### 5) Connecting charging unit

You can charge your S01 battery on the scooter or on its own. In either case, both the scooter and the battery have an IEC male contact for the power cable. The cable has an IEC socket contact and a Schuko contact (commonly used in Spain for the domestic grid), and is normally stored in the compartment under the seat, where the male power contact point is located. On the battery, it is on the back:



**Before removing or putting the battery pack on the scooter, make sure it is not charging nor has the key in the ignition.**

The charger (600W) is part of the battery pack, so all you need to charge the battery is a power point and the cable. It uses convection cooling.

- **To connect**, first plug in the IEC contact (scooter or battery) and then plug into the power grid. It is important to fully charge the battery after it has been partially used 3 or 4 times.

- **To disconnect**, first unplug from the power grid and then unplug the IEC contact. The charging process can be stopped at any time. Plus, the control system will stop charging the battery when it is at 100%.

If the battery temperature is under **0°C** or over **55°C** (due to improper use), it won't charge.

## IMPORTANT!

Charge the battery completely once every 30 days to keep warranty valid\*.

If plugged in when too cold, an internal heater will switch on until it reaches 15°C. This heater works when plugged into the grid and allows the power to be transferred at the right temperature. This, however, has an impact on charge time, which will take longer than if the temperature conditions are within the normal range.

For cold regions and seasons, we recommend keeping the battery plugged into the grid so the heater can warm the cells and keep them at the right temperature for the scooter to be used normally.

**\* To keep the battery warranty valid, you must fully charge (to 100%) the battery at least once a month.** If you know you won't be using it for a while, it is important to leave the battery with enough charge so that it doesn't reach critical levels. Batteries that fall below a certain level of voltage no longer work on their own, meaning they can't be charged and must be taken to an Official Service Centre.

## 6) Temperature

This scooter has a system that controls and stabilises the voltage and temperature of the cells. To avoid critical situations, the safety systems limit battery use if the cell temperature is above safe levels due to overheating.

- The battery can be used between -10°C and 65°C. The performance of the lithium cells may vary depending on the temperature.
- The charger won't charge the battery if the cell temperature is below 0°C or above 55°C.
- The current battery temperature is shown on the scooter display. If any of the limits are surpassed (upper or lower, warning or failure), the following light will come on:



Temperature light. This blinks if any part is near its maximum allowable temperature. It stays on without blinking when it is over the maximum temperature.  
Motor: 100°C (blinking), 110°C (steady). Controller: 70°C (blinking), 75°C (steady) BMS: 50°C (blinking), 65°C (steady) / -10°C (blinking), -15°C (steady)

The following actions, depending on the situation, should be taken:

- **Low temperature:** The battery isn't working under optimal conditions, charge the scooter.
- **High temperature:** Due to over-use, the battery can't provide any more power. Avoid Sport mode and stop the vehicle if necessary for it to cool down.

## 7) Charge gauge in % (SoC)

To get as precise a reading as possible for the state of charge (**SoC, as a %**), the battery has to be charged to 100% (at least after 3 or 4 partial charges).



## 8) Range

The range of an electric vehicle is the distance it can travel on a single charge of the battery.

This is influenced by many factors, including driving style, load and distribution, tyre pressure and weather conditions, such as wind, which can decrease the range.

The display shows an estimated number of kilometres (or miles) left. This is **approximate** and depends on driving style and current use of power:

## 9) Battery warnings

|   |   |
|---|---|
| <p><b>WARNING</b>  <b>NEVER OPEN THE BATTERY BOX</b></p> <p>THIS MAY BE HIGHLY DANGEROUS AND WILL TOTALLY VOID THE WARRANTY.<br/>ONLY AUTHORISED PERSONNEL MAY WORK ON THE BATTERY BOX.</p> <hr/> <p><b>IN THE EVENT THAT SMOKE STARTS TO ESCAPE FROM THE BATTERY, IT IS ESSENTIAL TO URGENTLY CALL THE FIRE BRIGADE (DANGER OF DEATH) AND REMOVE IT FROM THE ENCLOSED SPACE IN WHICH IT IS LOCATED.</b></p> <p><b>THE VEHICLE CANNOT EXPLODE, SO THERE IS NO PROBLEM IN TRANSPORTING IT TO A SAFE LOCATION.</b></p> | <p><b>WARNING</b></p> <p></p> <p>To prevent injuries, burns or electric shocks:</p> <ul style="list-style-type: none"> <li>- Never dismount the battery unit or remove its caps. Only authorised personnel are permitted to do so.</li> <li>- Keep children away from this part of the scooter.</li> <li>- Do not perforate or knock this zone when using hoists, expose to flames, incinerate, or expose to fluids, as the generation of excess heat may lead to fire which could be dangerous.</li> </ul> <hr/> <p><b>Qualified Authorised Personnel</b></p> <p>The workshop manual must be read before repairing or replacing the battery</p> <hr/> <p><b>Information Regarding Battery Recycling</b></p> <p>Once the useful life cycle of the Power Battery Pack of your S02 electric scooter is over, you will be able to deliver it to an authorized SILENCE service for its correct processing, thus reducing its environmental impact.</p> <p>Inform your nearest SILENCE service so that it can proceed to its collection and subsequent recycling.</p> |
|---|---|

### a) First aid

In the case of a broken battery, smoke or fire, evacuate people from the contaminated area and get as much ventilation as possible to clear out the gasses. Seek medical attention.

- Contact with eyes: Flush with water (eyes open) for at least 10 minutes.
- Contact with skin: Remove contaminated clothing and flush the affected area with soap and water for at least 15 minutes. Do not apply grease or pomades.
- Inhalation: Take outdoors and air out the contaminated area. Provide oxygen or artificial respiration if necessary.

### b) Fire protection

Extinguishing measures:

- Can be used: Type-D, CO<sub>2</sub>, dry chemical extinguishers.
- Specific hazards: cells overheating due to external heat sources or improper use.

## 10) Note - Lifespan of Power Battery Packs

When the lifespan of your S01 battery pack comes to an end, you can hand it in to an authorised SILENCE service centre to be processed properly, limiting its effect on the environment.

Notify your nearest SILENCE service centre so they can pick it up and recycle it.

### 3. MAINTENANCE SCHEDULE

As with any other vehicle on the road, regular maintenance and inspection is required before each use. This is the only way we can ensure our own safety and that of others on the road, while also guaranteeing an optimal experience on the scooter.

Always take your scooter to a SILENCE Official Service Centre, as they know your scooter best and have the right tools to diagnose and repair it. However, there are some things you can (and should) check yourself, such as tyre pressure, brake fluid, etc.

#### DISCLAIMERS

- These instructions were drafted for owners that will only use the S01 in urban areas. If you will use it for a purpose other than that for which it was intended or drive steadily at a high speed or in overly damp or dusty conditions, you will have to service the scooter more often.
- If your S01 is involved in an accident, request an inspection of the main components by a SILENCE Official Service Centre.
- Failure to properly maintain the scooter, follow instructions or solve a problem before driving could cause an accident in which there is a **SERIOUS RISK OF INJURY OR DEATH**. Always follow this programme and any advice from your SILENCE distributor.
- There are some basic operations you may be able to do on your own (those that are the same for a combustion-engine motorcycle, like changing the brake pads, for example). Only you can decide if you are capable and, therefore, whether or not you should do these tasks personally.
- Always read the instructions before starting and make sure you have all the materials you need and a clear idea of what you are going to do.
- Use the centre stand for any operations, always on a flat, hard horizontal surface.
- Always carry out any operations on the scooter after turning it off and removing the keys (unless indicated otherwise in the instructions) to avoid starting it accidentally and having an accident with the motor running.
- Take care with hot parts, above all the disc brakes just after driving your S01. Let them cool off first.

## A. OPERATIONS AND FREQUENCY

| ZONE                    | WHAT TO DO   | FREQUENCY      |
|-------------------------|--|----------------|
| <b>Painted pieces</b>   | Clean with shine restorer.   | Monthly        |
| <b>Rubber pieces</b>    | Clean with special products to protect the rubber.   | Monthly        |
| <b>Aluminium pieces</b> | Clean with protective spray to prevent rusting. Remove any rust on the aluminium carefully with steel wool and soap. | Weekly         |
| <b>Metal pieces</b>     | Use oil to clean and grease the metal pieces.  | Monthly        |
| <b>Saddle</b>           | Clean with a soft sponge to remove any insects or grime.   | Every day used |
| <b>Instrument panel</b> | Clean any hardened dirt with a soft sponge.  | As needed      |
| <b>Tyres</b>            | Make sure the pressure is 1.8 bar (front) and 2.5 bar (rear).  | Weekly         |
| <b>Lights</b>           | Clean any hardened dirt with a soft sponge.  | As needed      |
| <b>Screen</b>           | Clean with a soft sponge to remove any insects or grime.   | Every day used |

## B. CHECK BEFORE DRIVING

### 1) Charge level

Check the charge level on the LCD screen. If it is too low, recharge the battery before using your scooter:

### 2) Lights and indicators

Replace any parts that don't work properly or have been damaged before driving. When the speedometer lights don't work properly, they start blinking more quickly to indicate that there is some sort of problem.

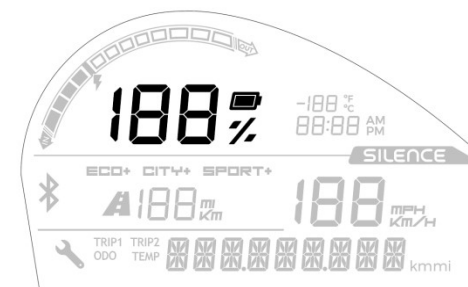



### 3) Stands

Make sure both the side stand and centre stand are folded away. The side stand has a sensor that prevents the scooter from being driven when it is out, but the centre stand doesn't.

### 4) Tyres

Always make sure there are no punctures, cracks or tears in the tyres, and that the treads are not worn down. Never drive with worn or defective tyres. **Make sure the front tyre pressure is 1.8 bar and the rear 2.5 bar.**

Driving with inappropriate tyre pressure can damage the tyre and cause an accident, in addition to limiting their lifespan.

#### Rear tyre

It is very important to respect the rear tyre pressure (2.5 bar) as the motor is inside the rear wheel.

It is important to remember that this vehicle has more weight on the rear wheel than conventional vehicles (those without an in-wheel motor), so the rim or motor can be affected when going over kerbs, potholes or road humps if travelling at the same speed as a conventional vehicle.

**WARNING: If you go over kerbs, potholes or road humps at high speed, you could damage the vehicle's rim and/or motor.**

### 5) Brakes

#### a) Brake fluid

The brake fluid tanks are located on the top of the handlebar, one on each side. Check the levels with the scooter resting on both wheels, not on either stand.

The brake liquid should never fall below the MIN line on the tank. Air can get into the tank if it is empty, which can cause problems in the scooter's braking system and compromise safety on the road.

**Levels should always be checked and the fluid must be changed every 2 years. If there is not enough fluid, add more.**

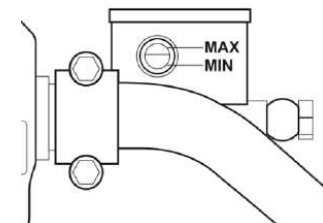



### b) Front brake

The brake pads have safety slots. If the slots in the friction material are visible, check your point-of-sale for replacements.

### c) Rear brake

When the rear brake pads are less than 1mm thick, they are less effective. Check with your point-of-sale for replacements. **USE DOT4 OIL** (Never mix new and used fluid).

**WARNING:** Brake fluid can damage the scooter's paint and plastic pieces if spilled

Brake fluid can cause damage and injuries if not handled properly and safely.

If you get brake fluid on your skin, wash it off immediately with water. If you get brake fluid in your eyes, flush with water and seek medical attention quickly.

### d) Brake lever

If you find the brake levers too loose, and the brake pads are still in good condition, take the scooter to the official point-of-sale as soon as possible to have it checked:

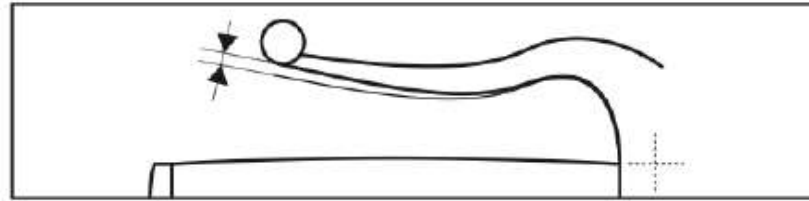

After the “D” icon lights up (scooter ready to drive), make sure the braking system is working properly: Squeeze the left and right brake levers at the same time to make sure there is resistance to the pressure.

Once the scooter ready light is on, you can release the brake levers. The system is working and the accelerator is ready to be used:

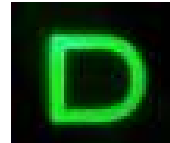

## C. SOLVING PROBLEMS

For the issues described here, we assume that only the final components are the cause of the problem.

If the problem continues after replacing the final component, take the scooter to the official point-of-sale.

All of our scooters are examined carefully before being sent to our distributor. Even though the scooters are carefully inspected, some issues may arise. The following table offers guidelines for identifying the problem and, if possible, repairing it yourself. If you can't resolve the problem on your own, take your scooter to the point-of-sale for the necessary repairs.

| PROBLEM   | CAUSE   | SOLUTION  |
|---|---|---|
| <b>Front lights don't work</b>                                | The component is defective or the connectors are damaged. Damaged fuses   | Check the connections, replace fuses and, if the problem persists, take the scooter to the nearest official distributor   |
| <b>Rear lights or brake lights don't work</b>                 | The component is defective or the connectors are damaged. Damaged fuses   | Check the connections, replace fuses and, if the problem persists, take the scooter to the nearest official distributor   |
| <b>Scooter doesn't accelerate</b>                             | Accelerator not adjusted properly. Check the connection between the accelerator and the electrical installation | Take the scooter to your nearest official distributor   |
| <b>Scooter won't start</b>                                    | Key not in the ignition<br><br>The scooter is charging<br>The battery is dead<br>Damaged fuses                  | Check that the key is in the ignition or that the scooter is activated using the app<br>Wait for the battery to charge and remove the charger<br>Charge the battery fully<br>Replace damaged fuses<br>If the problem persists, take the scooter to the nearest official distributor |
| <b>Battery won't charge. Battery percentage doesn't go up</b> | Problem with the battery, problem with the charger<br>Power not getting to the charger                          | Check the charger-battery and the battery-power grid connections. Check the connection between the charger and the power grid   |
| <b>Brakes don't work properly</b>                             | Wrong tyre pressure<br>Worn tyres<br>Too much weight loaded in the compartments                                 | The tyre pressure must be checked and at the proper level: front, 1.5 bar; rear, 2.5 bar.<br>Replace tyres<br>Check to see if the scooter is overloaded. Drive without carrying anything  |
| <b>Error in the state of charge reading</b>                   | The charge gauge is not in sync with the real state of charge   | Discharge the scooter battery until the green OK LED blinks seven times and it charges completely. Take the scooter to an official distributor if the problem persists.   |
| <b>Message on screen: "0X"</b>                                | Depends on the problem  | Take the scooter to your nearest official distributor   |

## E. CLEANING AND STORAGE (Guide to parking the vehicle)

### 1) Cleaning

Clean the scooter as indicated in the previous sections. As with any vehicle, the scooter must be cleaned regularly to keep it in good conditions.

It is the user's responsibility to properly protect the scooter from aggressive contaminants in the air and the effects of salt on the roads.

**WARNING: Don't clean the battery with a lot of water or a high-pressure washer.** Never use harsh detergents on the scooter. Try to find gentle cleaning products for the vehicle that are environmentally friendly.

When you dry your scooter, always use a clean cloth. Dirty cloths can scratch the flat, shiny surfaces and clean ones will reduce scratching. Never use hard cloths or sponges.

### 2) Storage

If you are not going to be using your scooter for a long period of time, always read and follow these instructions:

- Clean the scooter and let it dry **completely** before putting it away. Any water or dampness could cause problems in the electronic components.
- Put the scooter up on its **centre** stand.
- Check the scooter to make sure there haven't been any problems in the past.
- A **cover** to protect your scooter from the elements is a good investment.
- Put some type of **protection** on the floor to protect from any drips and prevent damage.

## 4. VEHICLE AND BATTERY WARRANTY

### A. DELIVERY TO BUYER

This document is the basis for processing any warranty claims (warranty claims cannot be processed if the documents are not filled in properly or are incomplete):

|   |  |
|---|--|
| <p><b>VIN (número de identificación del vehículo)</b></p> <hr/> <p>Nombre completo.....</p> <p>Calle.....</p> <p>Ciudad.....</p> <p>Código postal.....</p> <p>País.....</p> <p>Teléfono / Móvil.....</p> <p>e-mail.....</p> | <p>.....</p> <p><b>Fecha de Entrega</b></p> <hr/> <p><b>Número de Distribuidor</b></p> <hr/> |
|---|--|

## B. WARRANTY CONDITIONS

### (Grounds for voiding warranty)

**This vehicle has a two-year warranty (except special promotions offering a three-year warranty), from the date of delivery, covering any design and manufacturing defects.**

Parts subject to normal wear and tear, like tyres, disc brakes, brake pads, etc., are not covered by this warranty. The manufacturer and the chosen garage will decide which defective pieces will be replaced or repaired.

The warranty will be VOID if:

- a) The end user has not followed regulations in handling the vehicle.
- b) The end user has not done any or all of the inspections required in the service booklet or has taken the scooter to be repaired at an unauthorised garage (see the “INSPECTIONS” section).
- c) The vehicle has been modified or changed in any way or given parts not among its original features certified expressly by the manufacturer.
- d) The vehicle has been used in sporting competition.
- e) The operations, maintenance and service instructions established in this manual have not been followed.

**WARNING:** Normal use. At least once a week, for at least 10 hours.

Without regular use. The scooter should be fully charged before it is left parked for more than one week.

**The battery must be charged completely once every 30 days to keep the warranty valid.**

**Any agreements that differ from the warranty conditions above must be confirmed in writing by the manufacturer.**

## C. INSPECTIONS: SCOOTER & BATTERY

Each S01 must pass a series of periodic inspections, based on the kilometres travelled or at least once a year (if the scooter has not been driven the kilometres necessary to require an inspection within the past year). The same is true of the battery packs (*be*), which have their own inspection points. For batteries purchased with the scooter, the inspections will be the same as the scooter and must be passed at the same time.

The number of kilometres between inspections **of the scooter and the battery** is shown automatically on the scooter display panel (the screen will show a spanner icon to indicate that it is time for an inspection based on the kilometres travelled): first inspection at **1,500 km**, second at **5,000 km**, third at **10,000 km** and the following inspections **every 5,000 km**.

Inspections of the **scooter** must be done within one year of the previous inspection (**at least one per year**).

Information on what to inspect is provided in the corresponding manual/maintenance plans, for the scooter and for the battery, which are available to SILENCE Official Service Centres.

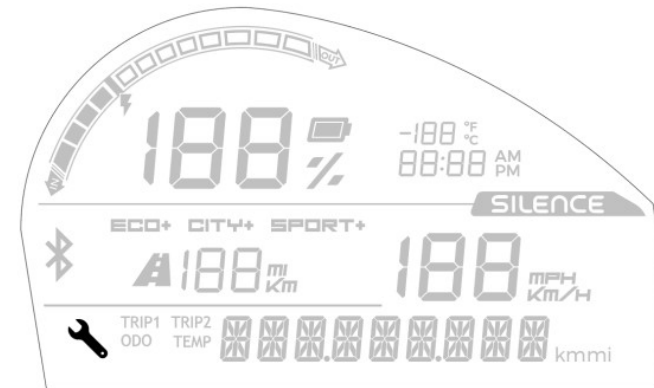



### Registry of inspections S01 (both scooter and battery):

| INSPECTION NUMBER                  | DATE                           | ODOMETER READING       | SIGNATURE OFFICIAL SERVICE |
|------------------------------------|--------------------------------|------------------------|----------------------------|
| <b>NUMBER PLATE</b>                | ...../...../.....              |                        |                            |
| <b>1st INSPECTION BEFORE:</b>      | +1 year ↓<br>...../...../..... | or 1,500 km<br>.....   | .....                      |
|                                    | must be greater than ↓         | must be greater than ↓ |                            |
| <b>INSPECTION INFO:</b>            | ...../...../.....              | .....km                |                            |
| <b>1st NEXT INSPECTION BEFORE:</b> | +1 year ↓<br>...../...../..... | +3,500 km ↓<br>.....km | .....                      |
|                                    | must be greater than ↓         | must be greater than ↓ |                            |
| <b>INSPECTION INFO:</b>            | ...../...../.....              | .....km                |                            |
| <b>2nd NEXT INSPECTION BEFORE:</b> | +1 year ↓<br>...../...../..... | +5,000km ↓<br>.....km  | .....                      |
|                                    | must be greater than ↓         | must be greater than ↓ |                            |
| <b>INSPECTION INFO:</b>            | ...../...../.....              | .....km                |                            |
| <b>3rd NEXT INSPECTION BEFORE:</b> | +1 year ↓<br>...../...../..... | +5,000km ↓<br>.....km  | .....                      |
|                                    | must be greater than ↓         | must be greater than ↓ |                            |
| <b>INSPECTION INFO:</b>            | ...../...../.....              | .....km                |                            |
| <b>4th NEXT INSPECTION BEFORE:</b> | +1 year ↓<br>...../...../..... | +5,000km ↓<br>.....km  | .....                      |
|                                    | must be greater than ↓         | must be greater than ↓ |                            |
| <b>INSPECTION INFO:</b>            | ...../...../.....              | .....km                |                            |
| <b>5th NEXT INSPECTION BEFORE:</b> | +1 year ↓<br>...../...../..... | +5,000km ↓<br>.....km  | .....                      |
|                                    | must be greater than ↓         | must be greater than ↓ |                            |
| <b>INSPECTION INFO:</b>            | ...../...../.....              | .....km                |                            |
| <b>6th NEXT INSPECTION BEFORE:</b> | +1 year ↓<br>...../...../..... | +5,000km ↓<br>.....km  | .....                      |
|                                    | must be greater than ↓         | must be greater than ↓ |                            |

| INSPECTION NUMBER                   | DATE                           | ODOMETER READING       | SIGNATURE OFFICIAL SERVICE |
|-------------------------------------|--------------------------------|------------------------|----------------------------|
| <b>INSPECTION INFO:</b>             | ...../...../.....              | .....km                |                            |
| <b>7th NEXT INSPECTION BEFORE:</b>  | +1 year ↓<br>...../...../..... | +5,000km ↓<br>.....km  | .....                      |
|                                     | must be greater than ↓         | must be greater than ↓ |                            |
| <b>INSPECTION INFO:</b>             | ...../...../.....              | .....km                |                            |
| <b>8th NEXT INSPECTION BEFORE:</b>  | +1 year ↓<br>...../...../..... | +5,000km ↓<br>.....km  | .....                      |
|                                     | must be greater than ↓         | must be greater than ↓ |                            |
| <b>INSPECTION INFO:</b>             | ...../...../.....              | .....km                |                            |
| <b>9th NEXT INSPECTION BEFORE:</b>  | +1 year ↓<br>...../...../..... | +5,000km ↓<br>.....km  | .....                      |
|                                     | must be greater than ↓         | must be greater than ↓ |                            |
| <b>INSPECTION INFO:</b>             | ...../...../.....              | .....km                |                            |
| <b>10th NEXT INSPECTION BEFORE:</b> | +1 year ↓<br>...../...../..... | +5,000km ↓<br>.....km  | .....                      |
|                                     | must be greater than ↓         | must be greater than ↓ |                            |
| <b>INSPECTION INFO:</b>             | ...../...../.....              | .....km                |                            |
| <b>11th NEXT INSPECTION BEFORE:</b> | +1 year ↓<br>...../...../..... | +5,000km ↓<br>.....km  | .....                      |
|                                     | must be greater than ↓         | must be greater than ↓ |                            |
| <b>12th INSPECTION INFO:</b>        | ...../...../.....              | .....km                |                            |