

GENERAL  
GENERAL  
GENERAL  
GENERAL  
GENERAL

**BIKE  
USER  
MAN-  
UAL**

ENGLISH

READ  
BEFORE  
YOUR  
FIRST  
RIDE





# GENERAL MANUAL

---

ENGLISH

# Contents

---

<b>INTRODUCTION</b>	<b>3</b>	<b>BIKE MAINTENANCE &amp; RANGE</b>	<b>22</b>
Greyp Bikes Disclaimer	3	Maintenance	22
General warning	4	Range	24
General information	4		
Safety information	5	<b>CLEANING THE BIKE</b>	<b>25</b>
General information about assembly	6	Chain	25
		Fork	25
		Shock	26
<b>GENERAL NOTES ABOUT RIDING</b>	<b>7</b>	Lubrication	26
Luggage carrier and kickstand (if equipped)	8		
Riding tips	9	<b>WARRANTY</b>	<b>27</b>
Pre-Ride Inspection	10	General	27
Riding tips for children	10	Battery	28
Seat post – basics	10	Frame	29
Brakes – basics	11	Motor	29
Gear system	12	Electronics	29
Suspension – basics	12	Brakes	29
Recommended tire pressure	12	Suspension	29
		Drivetrain	30
<b>BATTERY AND CHARGER</b>	<b>14</b>	How to file a claim	30
Battery technical data	14		
Important battery information	16	<b>DISPOSAL</b>	<b>31</b>
Battery life	21	Only for EC countries:	31



## Introduction

**Original instructions (user manual/instructions for use) are written in English. All other languages are translations of the original instructions (user manual/instructions for use). In case of any dispute, the user manual in English prevails.**

**The first volume is "GENERAL MANUAL" while the second is the "TECHNICAL MANUAL". If you didn't get either of them, please ask your retailer to send you one or download it from [www.greyp.com](http://www.greyp.com).**

This user instruction manual is developed for your Greyp bike only. It contains important safety, performance and technical information, which you should read before your first ride and keep for reference. You should also read the entire User Manual, because it contains additional important general information and instructions that you should follow.

*If you do not have a copy of the User Manual, please download it for free at [www.greyp.com](http://www.greyp.com) or obtain it from your nearest Authorised Greyp Retailer. In case of any discrepancy, the english version shall prevail.*

### Greyp Bikes Disclaimer

Any modifications of the bike are strictly forbidden and Greyp Bikes d.o.o. will bear no liability whatsoever for the consequences of such modifications. Greyp Bikes d.o.o. does not grant, explicitly or implicitly, to any party any patent rights, licenses or any other IP rights, whether with regard to such information itself or to anything described by such information. The information provided by Greyp Bikes d.o.o. hereunder is provided as is, where is and with all faults, and the entire risk associated with such information is entirely with the buyer. The information provided in this document is proprietary to Greyp Bikes d.o.o., and Greyp Bikes d.o.o. reserves the right to make any changes to the information in this document or to any products and services at any time without notice.

You should check [www.greyp.com](http://www.greyp.com) for any changes made in the User Manual.



**Greyp Bikes d.o.o.**,  
Ljubljanska 7, 10431 Sveta Nedelja, Croatia,  
15<sup>th</sup> of February 2020.

## General warning

This manual contains many "WARNINGS" and "CAUTIONS" concerning the consequences of failure to maintain or inspect your bike and of failure to follow safe cycling practices.

The combination of the safety alert symbol and the word WARNING indicates a potentially hazardous situation which, if not avoided, could result in serious injury or death.

The combination of the safety alert symbol and the word CAUTION indicates a potentially hazardous situation which, if not avoided, may result in minor or moderate injury, or is an alert against unsafe practices.

Many of the WARNINGS and CAUTIONS say *you may lose control and fall*. Because any fall can result in serious injury or even death, we do not always repeat the warning of possible injury or death.

As it is impossible to anticipate every situation or condition which can occur while riding, this User Manual makes no representation about the safe use of the bicycle under all conditions. There are risks associated with the use of any bicycle which cannot be predicted or avoided, and which are the sole responsibility of the rider.

## General information



**Important notice:** Please make sure you read this User Manual before operating a Greyp bike for the first time. It is very important to follow the instructions in the manual to make sure you use Greyp in the proper way. Greyp Bikes d.o.o. reserves the right to change the design, components and specifications at any time without notice and without any obligation. The illustrations and pictures in this manual are for demonstration purposes only.



**WARNING** — Please contact your dealer or manufacturer before trying to repair your Greyp bike. This User Manual is not intended as a service and repair manual.

Greyp bikes are classified as a pedelec. Greyp bike is a vehicle where the rider's pedalling is assisted by an electric motor with 5 assist and torque levels, which gives you a range of power assistance.

Before using your Greyp bike, please inform yourself of all applicable legal requirements and regulations in your country or state. There may be restrictions on riding your Greyp bike on public roads, cycling paths, and/or trails. There may also be applicable helmet requirements, age restrictions or license or insurance requirements. As laws and regulations regarding electric vehicles vary by country and/or state and are constantly changing, please make sure you obtain the latest information. You should also regularly see your authorized Greyp retailer for updated information.

All Greyp bikes have a fixed pre-set speed limit at which the motor support will automatically shut off. Tampering is to interfere with bike in order to cause damage or make unauthorized alterations (i.e. excluding the exchange of sprocket with non-original parts) Any (attempted) tampering with the power output and/or system (i.e. excluding the exchange of sprocket with non-original parts) is prohibited, will void the warranty, is extremely dangerous and could result in severe and/or fatal injuries. In case of tampering we recommend that you stop using bike and call authorized Greyp retailer.

## Safety information

Please, carefully read all the warnings and notes in this User Manual before using your Greyp bike.



**WARNING** – You add to your risk of injury when you use your bicycle in an incorrect manner. Misuse can add stress to your bike. High stress can cause the frame or a part to break and increase your risk of injury. To decrease your risk of injury, use your bicycle in the manner for which it was designed.



**WARNING** – As with all mechanical components, the EPAC (Electrically Power Assisted Cycles) is subjected to wear and high stress. Different materials and components may react to wear or stress fatigue in different ways. If the design life of a component has been exceeded, it may suddenly fail, possibly causing injuries to the rider. Any form of crack, scratches or change of colouring in highly stressed areas indicate that the lifespan of the component has been exceeded and it should be replaced.



**WARNING** – For composite components, impact damage may be invisible to you and may result in serious personal injury or death. If composite components exhibit any signs of damage, do not use them and immediately bring them to your authorized Greyp retailer for inspection.

The A-weighted emission sound pressure level at the driver's ears is less than 70 dB(A)



**WARNING** – Inappropriate handling of a Greyp bike can cause damage, injury and/or death. Please make sure you learn how to operate your Greyp bike in a safe and responsible way.

Greyp bikes are intended to transport only one person at a time. If you allow somebody else to use your Greyp bike, please provide them with this User Manual.

We advise keeping the original box that the bike came with for the warranty period in case there are any troubles.



**WARNING** – We strongly advise you to wear a helmet and other safety equipment while riding your bike. In some countries, there is an obligation to wear a helmet. Please check if this is the case in your country.

Only ride at ambient temperatures between 5°C (41°F) and 40°C (104°F).



**WARNING** – certain Greyp bikes are fitted with two pairs of lights, if applicable use single big white LED light mounted on fork as your main front light and single big rear red LED light (with build in Z reflector) for main rear light.



**WARNING** – Greyp lights (4 white LEDs on display unit - CIM and 4 red LEDs on rear camera - BUTS) are primarily designed as auxiliary lights and you should take care that you use lights that are in accordance with the provision in force in the country of use.



**WARNING** – Reflectors, which function only when light shines on them, are not a substitute for lights. Riding in dark conditions or at times of poor visibility without adequate lighting is extremely hazardous.



**WARNING** — Greyp bikes are not approved for child seats, towing child trailers, or any other type of trailers. Do not use child seats or bike trailers on luggage carrier.

### **General information about assembly**

This User Manual is not intended as a comprehensive use, service, repair or maintenance guide. Please see your authorized Greyp Bikes partner for all service, repairs or maintenance.



**WARNING** — Do not alter or modify any parts of your Greyp bike. Do not install incompatible components or hardware.

# 2

## General notes about riding

The motor provides pedal assistance while you are pedalling, and the the bike is in motion. The amount of pedal assistance will be higher or lower depending on the amount of force applied to the pedals. If you stop pedalling, the motor will stop providing any assistance. The Greyp bike can also be ridden as a normal bicycle without motor assistance by switching the vehicle to the OFF mode. The same applies if the battery is empty.

Greyp bikes have a walk-assist mode (the motor engages without pedal force being applied) which is designed to provide assistance when walking the vehicle up a hill.

The bike will be due for its first maintenance after roughly 100 kilometers or 62 miles, or 3 to 6 weeks. The running-in phase typically involves spokes losing tension, bolts losing tension, cables lengthening, gears becoming maladjusted, and bearings running in, so there is every reason to have your dealer service the bike at this stage. This maturing process is unavoidable. Therefore, make an appointment with your Greyp dealer or local bike service for a first inspection of your new bike. The first inspection is very important for the functioning and durability of your bike.

It is advisable to have your bike serviced regularly after the running-in phase. The schedule given in the technical manual is a rough guide for cyclists who ride their bike between 1,000 and 2,000 km a year. If you consistently ride more or if you ride a great deal on poor road surfaces, the maintenance periods will shorten respectively.



**WARNING** — The intended use of the bike includes regular maintenance and the replacement of worn out parts in time and therefore has an influence on the warranty as well.



**WARNING** — It is forbidden to install a child seat on luggage carrier handlebars, seat post, top tube of the frame, head tube of the frame, or any other place which is not designed for the installation of a child seat. Failing to follow these instructions can lead to serious damage to bike, injury or death.



## Luggage carrier and kickstand (if equipped)

A luggage carrier is a device that can be used to transport luggage. There are a variety of accessories available for these luggage system carriers, such as baskets or bags that lock in place on the luggage area.



**WARNING** – Do not make any alterations to the luggage carrier.



**WARNING** – Luggage can only be safely carried on the carrier.



**WARNING** – When the luggage carrier is loaded, the bike may behave differently i.e. braking distance may be longer, stability may be compromised and turning capacity may be lowered.



**WARNING** – Please make sure that any luggage fitted to the luggage carrier is securely fitted and that there are no loose straps that can get in the wheel. Always ensure that it is not possible for tensioning belts or cables to get into moving parts, e.g. the rotating rear wheel or the pedal crank.

When loading your bike, ensure that reflectors or lights continue to be visible. We advise that you distribute the luggage evenly between both sides of the luggage carrier.

For maximum allowed wheel size and tire for luggage carrier on Greyp bike check technical manual under "Appropriate spares: Front and Rear tire".

The maximum load limit of luggage carrier is 25kg. Do not overload the luggage carrier. Load the luggage carrier evenly. Make sure that the luggage is adequately secured to prevent it falling off.

Some Greyp bikes are equipped with a kickstand. A kickstand is a device for parking the bike in an upright position after use.



**WARNING** – Make sure that there is no additional weight on the bike when using the kickstand, as exceeding the load limit can cause the bike to fall over and cause serious damage or injury.

## Riding tips

Below are some riding tips, which may also reduce component wear and increase battery range.

- » *Pay attention to your speed when going into a corner and be sure to stop pedalling well before entering the corner. Otherwise you may have too much speed as you enter the corner;*
- » *Ride efficiently and look ahead. Any time a braking force is applied, more energy is needed to get the vehicle back up to speed;*
- » *Shift gears regularly to stay in an optimal cadence range and downshift before coming to a stop;*
- » *Reduce pedal force before initiating a gear shift to reduce drivetrain wear;*
- » *Check the tire pressure regularly. Low pressure can cause the tires to roll inefficiently;*
- » *If your vehicle is exposed to cooler weather, keep the battery stored indoors until just before riding;*
- » *Do not expose your vehicle to excessive heat;*
- » *Only carry the cargo you need. More cargo weight requires more energy to move.*



**WARNING** — An improper derailleur shifting technique could cause your chain to jam or come off, causing you to lose control and fall.

Only shift one gear at time. When shifting gears make sure you ease up on the power and pedal lightly during the whole duration. Shifting gears under heavy load or shifting more gears at the same time can cause premature wear and damage to your drivetrain.

## Pre-Ride Inspection

- » *Prior to the first ride, charge the battery to 100%;*
- » *Check to ensure that the quick-release levers or axle nuts are tight;*
- » *Check the brake pads for excessive or uneven wear;*
- » *Make sure that all bolts on the brakes and steering parts are tight;*
- » *Spin the rims – check for wobbles;*
- » *Check the tire pressure;*
- » *Check the tires for excessive wear, cracking or gashes;*
- » *Check that the gears shift smoothly;*
- » *Check the chain for rust, dirt, stiff links or noticeable signs of wear (the chain should be clean and lubricated, be sure to use a chain-elongation gauge);*
- » *Apply the front brake, and push the bike forward and backward (the headset should be tight and not make any clunking noises).*



**WARNING** – Being aware of your surroundings can drastically reduce incidents. If you are on the road be aware of traffic and road conditions. In off-road conditions there may be less friction between the tires and the ground and it can make you lose control and cause an accident.



**CAUTION** – Your field of view is particularly shorter, in fact very short, when riding at night. Obstructions are more difficult to see at night. Use extreme caution, slow down to compensate for the much shorter reaction time and ride at a speed appropriate to your field of vision and surroundings.

## Riding tips for children

Greyp bikes are only designed and tested for use by one person at a time. Greyp bikes are not intended for children under 16 years. Do not allow children under 16 years old to drive a Greyp bike.

## Seat post – basics



**WARNING** – Make sure that the seat position is adjusted so that the feet of a seated rider can touch the ground. If your bicycle does not fit properly, you may lose control and fall.



**WARNING** – After any saddle adjustment, be sure that the saddle adjusting mechanism is properly seated and tightened before riding. A loose saddle clamp or seat post clamp can cause damage to the seat post, or can cause you to lose control and fall. Use the ball of your thumb to press the lever. A correctly tightened saddle adjusting mechanism will allow no

saddle movement in any direction. Periodically check to make sure that the saddle adjusting mechanism is properly tightened.

Certain Greyp bikes have a telescopic seat post. Familiarise yourself with the features of the seat post before your first ride. Only operate the telescopic seat if it will not take away your attention from the road and terrain. Most of Greyp bikes with a telescopic seat post have information from the telescopic seat post manufacturer (check technical manual) ([www.kssuspension.com](http://www.kssuspension.com)). A telescopic seat post allows the saddle height to be adjusted by operating a lever underneath the saddle or a remote control on the handlebars, both at a standstill and while riding.

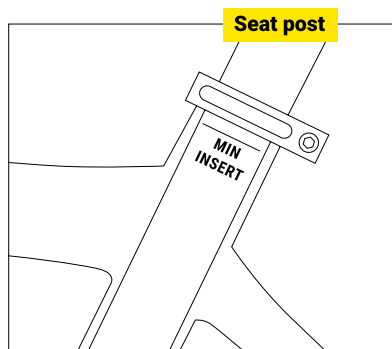

To lower the saddle, weight the saddle firmly with your hand or sit on the bike while pressing and holding the actuation lever or remote. Release the lever when the desired height is reached.

To raise the saddle, actuate your seat post by pulling the lever or pressing the handlebar remote. Unweight the saddle and release the lever when the desired height is reached.

You can raise and lower your saddle to any desired position within the seat post's travel.

The saddle height is always measured with the crank arm pointed down and in line with the seat tube. The distance from the centre of the pedal axle to the top of your saddle is your saddle height. Before changing the height of your saddle, you should measure your current saddle height.

All seat post models must be inserted into the bike seat tube to cover the minimum insertion line indicated on the seat post. Insufficient insertion of the seat post into the bike's frame seat tube could result in damage to the seat post and/or vehicle and may result in a loss of control, which may lead to serious injury or death.

## Brakes – basics



**WARNING** – Braking devices on Greyp bikes are a high-performance product, offering a stopping power greater than on regular bikes. As a result, less effort is required to lock up the wheel when braking. Be careful, as a locked wheel can result in loss of control over the vehicle and can cause injuries. Brakes are essential for the safe use of a vehicle - an improper setup and use of the brakes can make you lose control and cause an accident, with unpredictable consequences and/or potentially serious injuries. Disc brakes get VERY hot when used. Commonly the left lever operates the front brake and the right lever operates the rear brake (this may vary depending on country).



**CAUTION** – NEVER touch the calliper or the rotor immediately after use. Make sure the brakes have cooled down before working on them.

The brake rotors must be installed on wheels that are suitable for this type of brake system. A wheel with an insufficient spoke section or with radial spoke lacing can break under normal use of the braking system and cause serious injury, accident or death. Check with your wheel manufacturer BEFORE installation to ensure compatibility.

Check the spoke tension and condition frequently. A damaged spoke may break suddenly and interfere with the braking system. This may result in serious personal injury, accidents or death.



**WARNING** – Before every ride, make sure there are no fluid leaks in the system by applying the lever and holding it down as far as it will go. Check the hose connections and the brake fluid reservoir for any leaks. Consult a professional mechanic if there are fluid leaks. A fluid leak can cause a serious accident or death.



**CAUTION** – Braking distances may be greater in wet weather and using the brakes improperly can make you lose control, fall and cause an accident.

Test the brakes and your braking technique on flat and even ground before using the bike in more severe conditions.

You can find more info about Formula Cura brakes on [www.rideformula.com](http://www.rideformula.com)

## Gear system

If you cannot change gear cleanly, you need to make adjustments to the gear system on the shifting level housing. Gradually unscrew the adjuster on the shifting lever housing with your fingers and check the functioning of the gears after each turn.

On some systems, to be able to turn the adjuster, you need to pull it out of position slightly. Make sure that it is back in position before you check the functioning of the gears. If you cannot adjust the gear shifting using this method, the system must be checked by the professional bike mechanic.

## Suspension – basics



**WARNING** – Improperly installed, maintained or adjusted components are extremely dangerous and could result in severe and/or fatal injuries. If you have any questions about the installation of these components, consult a qualified bicycle mechanic.

## Recommended tire pressure

The tire pressure is an important factor for riding your bike properly. If the tire pressure is too high, the tire will not conform to the ground, reducing traction. It is important to have an accurate pressure gauge when setting the tire pressure; preferably a digital gauge with a 0.03 [bar] (0.5 [psi]) accuracy.

The recommended tire pressure will vary slightly based on rider weight, riding style, and terrain. Some riders may find it helpful to start a ride at a slightly higher pressure than recommended and let out a little air throughout the course of the ride until they find their ideal riding tire pressure.

***For the maximum inflation pressure check technical manual.***



**WARNING** — If the maximum pressure values in this manual and values on the side wall of a tire are in any way different, please refer to the ones that are marked on the tire's sidewall or wheel (which ever is lowest). Never inflate a tire beyond the maximum pressure marked on the tire's sidewall. Exceeding the recommended maximum pressure may blow the tire off the rim, which could cause damage to the bike and injury to the rider and/or bystanders.

You can find the minimum recommended tire pressure on the tire side wall. Never inflate tire below the minimum recommended tire pressure. If the tire pressure is too low, the tire could pinch flat and be difficult to handle and can cause loss of control.

# 3

## Battery and charger

Your bike is powered by a Lithium-ion (Li-ion) battery. Always adhere to the following instructions when handling or charging the battery or when using your Greyp bike. Only use the Greyp battery with the corresponding Greyp bike. Do not use the Greyp battery with other products or any other battery with the Greyp bike, even if it fits.

Turn off the bike, unplug the charger from the bike and remove the battery from the bike before performing work of any kind, such as installation, maintenance, cleaning and/or repair. When transporting or handling the battery separately from your Greyp bike, ensure the battery is turned OFF (you can do this by plugging the battery to the bike and if the bike doesn't turn on by itself that means that the battery is turned OFF). Touching the contacts when the battery is ON can result in electric shock and/or injury.

Before riding your bike, make sure the battery is properly secured in the frame.

Do not modify, open or disassemble the battery or charger, as modification or disassembly may result in a short circuit electric shock, fire or malfunction.

Be careful when handling the battery and do not drop it. Keep the battery out of reach of children and animals.

### Battery technical data

#### GREYP BATTERY PACK INFORMATION

**MANUFACTURER:** GREYP BIKES D.O.O.

**MODEL/TYPE REFERENCE:** G6-02

**WEIGHT:** 3.5 Kg

**BATTERY TYPE DESIGNATION:** 10INR19/66-6

**CELL CONFIGURATION:** 10S6P

**CAPACITY (AH):** 19.3 Ah

**ENERGY (WH):** 700 Wh

## GREYP G6 BATTERY PACK INFORMATION

<b>COMMUNICATION:</b>	CAN
<b>APPLICATION USING ENVIRONMENT:</b>	INDOOR AND OUTDOOR, -20~50 °C [-4~122°F]
<b>COOLING:</b>	NATURAL CONVECTION
<b>CHARGING</b>	BETWEEN 0-40°C [32~104°F]
<b>PROTECTION:</b>	PROTECTION TYPE: FUSE/ CELL CHRGM TEMP, DISCHRG TEMP / CELL VOLTAGE PROTECTION RATING : 40 A/ 0°C [32°F] TO 55°C [131°F] , -20°C [-4°F] TO 60°C [140°F] / 2.5 TO 4.19 VOLTS OVERLOAD PROTECTION: 30 A, 5 s SHORT CIRCUIT PROTECTION: 150 A
<b>OTHER INFORMATION:</b>	CELL INFORMATION : LG INR18650-MJ1, Li-Ion, 3.63V, 3500mAh OUTPUT CONNECTOR: RoPD TYPE, AUTOMOTIVE, 48V, 30A, UV RESISTANT
<b>CHARGING METHOD:</b>	CC/CV
<b>I CHARGE MAX:</b>	9.0 A
<b>I CHARGE:</b>	4.0 A (OPTIONAL: 8.0 A)
<b>I DISCHARGE:</b>	20.0 A CONTINUOUS
<b>U CHARGE MAX:</b>	42.0 V
<b>U CHARGE NOM:</b>	36.3 V
<b>U DISCHARGE END:</b>	25.0 V
<b>U CHARGE END:</b>	41.9 V





## Important battery information

**WARNING** – Failure to follow the instructions in this section may result in damage to electrical components on your bike and will void your warranty, but most importantly, may result in fire, chemical burn, electrolyte leak and/or serious personal injury or death. If your battery or charger exhibits any signs of damage, do not use it and immediately bring it to your authorized Greyp Bikes retailer for inspection.

The connector used for the battery and charger is magnetised (RoPD) and can attract metal objects. Do not allow any screws or other small, sharp and/or metallic objects to come in contact with the battery connector, bike charging socket or charger connector.

When storing, transporting, or cleaning the bike and/or battery, always use the plastic connector caps supplied.

Lithium-ion batteries are extremely sensitive to high temperatures and are inherently flammable. Lithium-ion battery packs tend to degrade much faster than they normally would due to heat. If an event causes the battery to ignite, use a Class – D fire extinguisher only (do not use water), do not inhale smoke and immediately call the fire department.

If a lithium-ion battery pack fails, it will burst into flames and can cause explosion and widespread damage. When ignited lithium-ion batteries fire spreads quickly and burns in intense heat. Smoke from lithium-ion battery fire is toxic.

Store the battery in a cool, dry, safe and isolated area away from any flammable objects.

The charging of a lithium-ion battery should always take safe, isolated, and vented area from any flammable objects and under supervision. When the battery is full, immediately disconnect it from the charger. Leaving the battery on a charger can cause it to fail. Do not leave a full battery on a charger.

Never charge the battery near flammable materials or objects. Also, do not charge the battery in places where high temperatures or sunlight are to be expected. Since heat is generated by the charging process itself, you should never cover the battery while charging.

Before you plug in the battery or charger, always check the battery connector, bike charging socket and charger connector for any damage or foreign objects. In case of any damage do not connect the battery or battery charger and please contact your authorized Greyp retailer. In case of a foreign object please safely remove it with non-conductive material before you connect the battery to your Greyp bike.

Do not leave a full or an empty battery for any period of time. Leaving a battery full can cause internal damage of the battery which than can burst into flames and can cause widespread damage. Keep the battery away from metal objects or any conductive material, as they can cause a short-circuit.

Do not allow the battery to overheat. Do not leave the battery exposed to a heat source or in a high-temperature location, ie in the sun in an unattended vehicle. To prevent the possibility of damage, store the battery out of direct sunlight. Do not expose the battery to fire, radiator heat, explosion or other hazards. Every time you detach the battery from the bike, put the plastic connector cap on the battery connector to prevent battery damage.

When storing, transporting, or cleaning the bike and/or battery, always use the plastic connector caps supplied.





Do not immerse the battery in water. Do not spray the battery, charger or the connectors with water. If you notice water may have got into the battery, slowly move the battery to a fire safe, isolated area away from anything flammable, and contact Greyp bikes or an authorized bike dealer.

In the event of an inadequate connection between the charger connectors and the battery connector or charging socket there could be functional problems and it is a potentially hazardous situation. In this case you should disconnect the charger connector and the battery and check what caused the inadequate connection.

Do not use a battery that shows any signs of damage (hollow casing, cracked lid, cracked connector, damaged connector) or is leaking any fluids. Slowly move the battery to a fire safe, isolated area away from anything flammable, and contact Greyp bikes or an authorized bike dealer. Battery liquid can cause skin irritation and burns. In the event of damage that results in skin or eye contact with any liquid from the battery, immediately flush with water and seek medical assistance.

The battery is heavy. Be careful when handling it and do not drop it. If any excessive outside force (ie: dropping the battery, hitting the battery with a hard object) happens, immediately take the battery to a fire safe location and contact Greyp bikes or an authorized bike dealer, as this can cause an internal short circuit - which can cause a runaway thermal event and cause the battery to catch fire. If you see/observe any damage or anything unusual on the battery (i.e., dent, hole or rupture of the battery or tubing, smoke, smell, swelling, noise, heat), immediately turn off the bike, unplug the bike or the battery from the power source (if connected) and slowly move the bike/battery to a fire safe, isolated area away from anything flammable, and contact Greyp or an authorized bike dealer. If you can do it, safely remove the battery from the bike. Use fire protective gloves to avoid touching the battery with your bare skin.

Do not connect the battery connector, bike charging socket or the charger connector if it is wet. You can use a dry cloth to dry the battery connector, bike charging socket or charger connector. It is important that you follow the instructions on the label of the battery charger and always use an appropriate Greyp charger.

The battery can be charged whether it is installed in the bike or not. Refer to the appropriate instructions regarding removing and installing the battery. Only charge the battery at an ambient temperature between 0°C and 40°C (32°F and 104°F). If the outside temperatures are too hot or too cold, charge the battery inside. For safety reasons, if the battery is too hot or too cold, it will not charge.

Do not cover the venting membrane at any time. Covering the venting membrane can lead to the battery overheating - which can cause a runaway thermal event and cause the battery to catch fire.

Do not insert anything in the venting membrane openings on the battery lid. If dirt is stuck in the venting membrane openings, use a soft brush to clean it. If you notice any punctures on the venting membrane, immediately stop using the battery and contact Greyp or an authorized bike dealer.

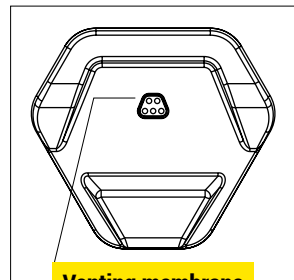

**Venting membrane**



## ON THE BATTERY

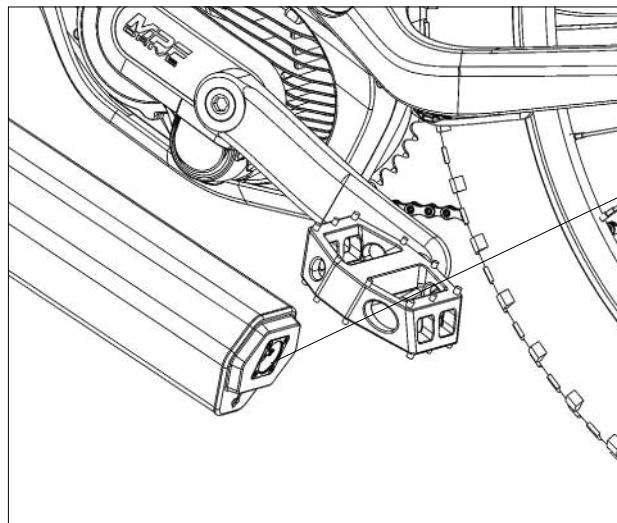

Charging socket

## ON THE BIKE

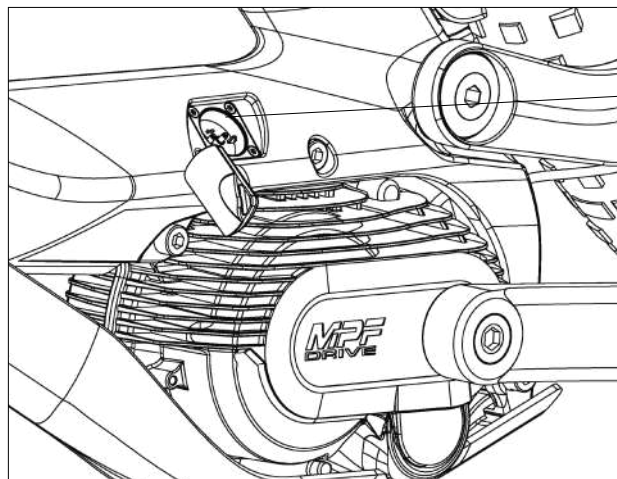

Charging socket

Plug the charger plug into an appropriate AC outlet (depending on the charger) using the appropriate plug/adaptor for your country's standard.

Uncover the charging socket on the bike, then connect the charger to the charging socket on the bike. It is possible to charge the battery when removed from the bike. In that case, plug the charger into the battery socket.

During the charging process, the light on the charger will glow red. When the battery is fully charged, the light on the charger will turn green. When monitoring the charging process, please check the LED light on the charger.

When charging is complete, disconnect the charging plug from the battery socket. Unplug the charger from the wall socket.

Make sure that the input voltage of the charger is in range of the power grid voltage you plan to use.

If the battery was left plugged in to the charger after reaching 100% SoC, the charging will stop. It can only be resumed by unplugging and plugging in the charger again.



**CAUTION** – If the red LED light is flashing during the charging process, a charging error has occurred. In that case, immediately remove the charger from the socket, discontinue the use of the motor support and contact an authorized Greyp retailer.

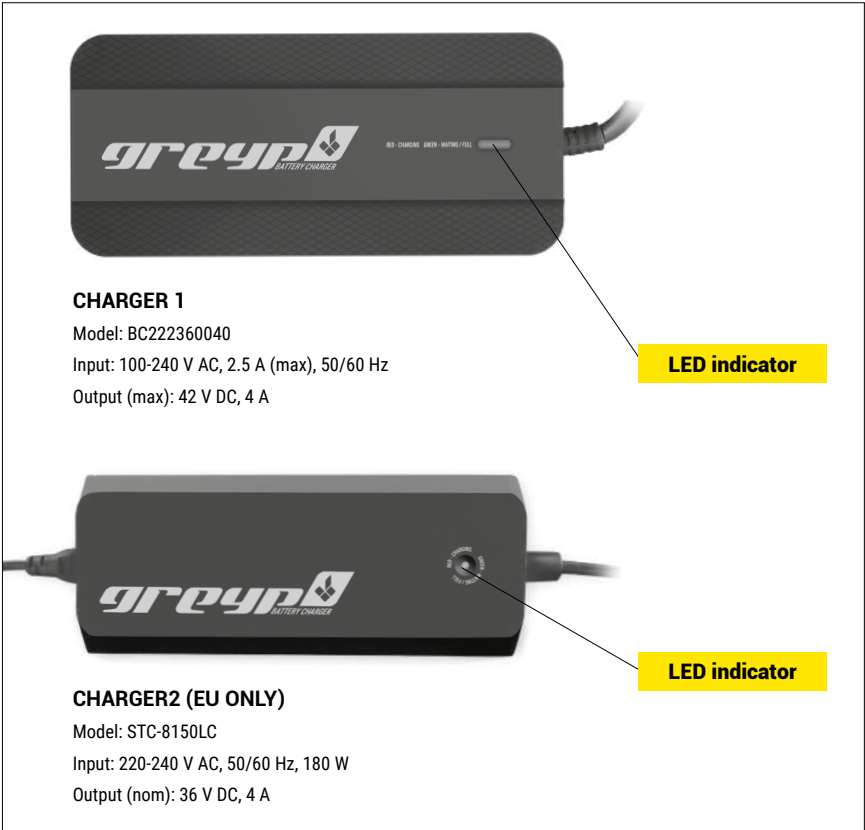

## Battery life

The bike should be stored in dry conditions. If you plan to store the battery for a period longer than a few weeks, please make sure that the SoC (State of Charge) is between 30% and 60%. It is necessary to check the battery frequently, even if the bike is not being used, in order to avoid permanent damage to the battery.

Strongly reduced operating time after charging can be a sign that the battery is reaching the end of its useful life and must be replaced. Provided your Greyp bike has been used properly, approximately 80% of the battery's original capacity should remain after 500 charging cycles or two years.

Recharging the battery takes approximately 5 hours. It is recommended that you don't wait for the battery to completely empty before recharging. Do not leave a full or empty battery for a longer period of time, as this will reduce the battery life. Try to keep the battery between 20%-80% to extend the battery life. If you know that your planned route is shorter and you don't need a full battery, we recommend that you charge the battery up to 80% of SoC instead of 100%. This way you will keep a better battery life.

The worst thing you can do is to leave a completely empty battery uncharged or a completely full battery for a longer period of time. This could lead to a reduced battery life, fire or permanent damage to the battery pack.

If the battery hasn't been used for 16 days consecutively, it will automatically lower the SoC (State of Charge) to 60%, to reach optimal storage conditions. The Self-discharge Procedure will be performed even if you leave the battery on a charger for longer than 16 days. If the battery SoC gets below 60%, it will automatically shut down.

Make sure to always power OFF the bike when you finish using it. If you are not using the bike for a longer time, check the battery SoC a day before the planned ride.

# 4

## Bike maintenance & range

### Maintenance



**WARNING** – Failure to follow the instructions in this section may result in damage, serious personal injury or death. If your bike exhibits any signs of damage, do not use it and immediately bring it to your authorized Greyp Bikes retailer for inspection.

All regular maintenance, troubleshooting, repair and parts replacement must be performed by an authorized Greyp retailer.



**WARNING** – If your use of a bicycle applies more stress than that which is intended, the bicycle or its parts can be damaged or broken. A bicycle that has damage could decrease your control and cause you to fall. Do not ride in conditions that apply more stress than the limits of the bicycle. If you are not sure of the limits of the bicycle, consult your bike shop.

Great care should be taken to not damage carbon fibre or composite material. Any damage may result in a loss of structural integrity, which may result in a catastrophic failure. This damage may or may not be visible on inspection. Before each ride, and after any crash, you should carefully inspect your vehicle for any fraying, gouging, scratches through the paint, chipping, bending, or any other signs of damage. If discovered, do not ride any further and take your Greyp bike to an authorized Greyp retailer for a complete inspection.

The lifespan and type and frequency of maintenance depend on many factors, such as frequency and type of use, rider weight, riding conditions and/or impacts. Additionally, the Greyp bike uses a power-assisted drive system, which means more distance at different rates, depending on the component. The drivetrain and brake components are especially subject to wear. Have your authorized greyp retailer inspect your vehicle and components periodically.

Exposure to harsh elements, especially salty air (such as riding near the ocean or in the winter) can result in galvanic corrosion of components, which can accelerate wear and shorten the lifespan of your bike. Dirt can also accelerate the wear of surfaces and bearings. The surfaces of the bike should be cleaned before each ride. Proper care and regular maintenance can help increase the longevity of components. If you notice any signs of corrosion or cracking on the frame or any component, the affected item must be replaced. While riding, listen for any creaks, as a creak can be a sign of a problem with one or more components. Periodically examine all surfaces in bright sunlight to check for any small hairline cracks and if you discover any, no

matter how small, or any damage to components, immediately stop riding and have the part inspected by your retailer. The vehicle should also be maintained regularly by an authorized Greyp retailer, which means it should be cleaned and lubricated. Regularly clean and lubricate the drivetrain according to the drivetrain manufacturer's instructions.

Do not apply lubricant on the disc brake rotors. Lubricant on brake surfaces can cause decreased braking function, and increase the possibility of an accident or injury. If any lubricant or any other fluid gets on the brake disc rotor, remove the wheel from the bike and clean the brake disc rotor thoroughly. If you get any on the brake pads, replace them.

Do not use a high-pressure water spray directly on the bearings. Even water from a garden hose can penetrate the bearing seals and crank interfaces, which can result in increased bearing and crank wear, in turn affecting the normal function of the bearings. Use a clean, damp cloth and bicycle cleaning agents for cleaning. Do not expose the vehicle to prolonged direct sunlight or excessive heat, such as inside a car parked in the sun or near a heat source such as a radiator.

It is very important that you use only original replacement parts for safety-critical components.

Bicycle wheel rims are subject to wear. Ask your dealer about wheel rim wear. Riding a wheel that is at the end of its usable life can result in wheel failure, which can cause you to lose control and fall.

Loose or damaged handlebar grips, end plugs or extensions should be replaced, as they can expose the ends of the handlebar, which have been known to cause injury, and they can cause you to lose control and fall.



**WARNING** — Riding with an improperly secured wheel can allow the wheel to wobble or fall off the bicycle, which can cause serious injury or death. Therefore, it is essential that you:

1. Ask your dealer to help you make sure you know how to install and remove your wheels safely.
2. Understand and apply the correct technique for clamping your wheel in place.
3. Each time, before you ride the bike, check that the wheel is securely clamped.
4. The clamping action of a correctly secured wheel must emboss the surfaces of the dropouts.

**The following parts must only be replaced with original components:**

- |                          |                       |
|--------------------------|-----------------------|
| » <i>Frame</i>           | » <i>Brakes</i>       |
| » <i>Battery</i>         | » <i>Charger</i>      |
| » <i>Display unit</i>    | » <i>Motor unit</i>   |
| » <i>Electric wiring</i> | » <i>Control unit</i> |
| » <i>Brake hoses</i>     | » <i>Sensors</i>      |

## **Range**

**The range on one charge greatly depends on several circumstances, such as (but not only):**

- |                                                                       |
|-----------------------------------------------------------------------|
| » <i>Weather conditions such as ambient temperature and wind;</i>     |
| » <i>Road conditions such as elevation and road surface;</i>          |
| » <i>Bike conditions such as tire pressure and maintenance level;</i> |
| » <i>Bike usage such as acceleration and shifting;</i>                |
| » <i>Rider and luggage weight;</i>                                    |
| » <i>Charge and discharge cycles.</i>                                 |



# 5

## Cleaning the bike

---

**Most cleaning can be done with soap, water, sponges and brushes.**

- » *Avoid using high-pressure sprayers because water can penetrate through seals ;*
- » *Avoid using corrosive soaps and strong solvents – always use cleaning products intended for an electric bicycle ;*
- » *For an extremely dirty chain we recommend using a solvent-bath chain cleaner.*
- » *Remove the battery before cleaning the bike.*

### **Chain**

After every wash, the chain should be wiped and lubricated. After every few rides, lube slightly. After every 400 km [250 mi], check for chain elongation. Use a chain-elongation gauge to determine whether the chain should be replaced.

### **Fork**

Wipe and clean the forks after every ride.

Performing the right maintenance on your fork not only ensures years of worry-free riding, but will also keep performance optimal and enhance your experience on the bike. Each service interval indicates the maximum number of riding hours designated for each type of recommended maintenance. Depending on the terrain and environmental conditions in your location, your riding style and skill level, you may see more optimum performance if you service your fork at shorter intervals. For specific detail check the suspension manufacturer service manuals.

## **Shock**

Wipe and clean the shock after every ride.

Performing the right maintenance on your shock not only ensures years of worry-free riding, but will also keep performance optimal and enhance your experience on the bike. Each service interval indicates the maximum number of riding hours designated for each type of recommended maintenance. Depending on the terrain and environmental conditions in your location, your riding style and skill level, you may see performance if you service your at shorter intervals. For specific details, check the suspension manufacturer service manuals.

Have all repairs performed only by an authorised bike dealer.

## **Lubrication**

Consult with your retailer to choose among the many types of chain lubes best suited to your climate and riding conditions. Every month, lubricate all of the pivot points of the rear derailleur, as well as on the jockey wheels.

# 6

## Warranty

---

### General

Greyp products have been manufactured and tested to the highest quality standards by Greyp Bikes d.o.o. This limited warranty offered by Greyp Bikes d.o.o. covers defects in material or workmanship in new Greyp products. Greyp warrants this product against defects in material or workmanship for a period of 24 months after the first purchase. Greyp will replace any product or part of the product that proves defective due to improper workmanship and/or material, under normal installation, use, service and maintenance. If Greyp is unable to provide a replacement and if a repair is not practical or cannot be made in a timely fashion, Greyp may elect to refund the purchase price in exchange for the return of the product.

This warranty extends to the original purchaser only and is non-transferable. This warranty does not apply to rental or commercial use bicycles. Only consumers purchasing Greyp products from authorized Greyp retailers or resellers or through the Greyp website may obtain coverage under our limited warranties. This warranty does not cover any damage or defects resulting from a failure to follow instructions in the user manual, alterations to the original design, acts of God, accident, misuse, neglect, abuse, improper assembly, operator error, water damage or improper follow-up maintenance. Greyp explicitly exempts from coverage any damage to bicycles used for jumping, stunt riding, rental programs, observed trials and any similar extreme riding or events.

Incidental and consequential damages are also not covered. Greyp does not cover the cost of international warranty shipping at any time, for any reason. This warranty is expressly limited to the replacement of defective parts with those of equal or greater value at the sole discretion of Greyp Bikes d.o.o.

The repair, replacement or refund of the purchase price, as provided by this warranty, is the exclusive remedy of the purchaser. Greyp Bikes neither assumes nor authorizes any person to create for it any other obligation or liability in connection with this warranty. Greyp Bikes shall not be liable to the purchaser or any other person for any incidental, special or consequential damages, arising under this warranty or any implied warranty, including without limitation, damages for personal injury, property damage or economic losses, whether based on the contract, warranty, negligence or product liability in connection with their products.

Some components of Greyp bikes are subject to wear and tear due to their function. The rate of wear will depend on care and maintenance and the way the bike is used. Bikes that are often

left in the open may also be subject to increased wear through weathering. The components below require regular maintenance. Nevertheless, sooner or later they will reach the end of their service life, depending on the conditions and intensity of use. The following parts that have reached their limit of wear and tear must be replaced :

- |                                  |                              |
|----------------------------------|------------------------------|
| » <i>Battery</i>                 | » <i>Brake hoses</i>         |
| » <i>Chainrings and cassette</i> | » <i>Lubricants</i>          |
| » <i>Drive chain</i>             | » <i>Dropper post seals</i>  |
| » <i>Hubs and free hubs</i>      | » <i>Suspension elements</i> |
| » <i>Brake pads</i>              | » <i>Wheels and spokes</i>   |
| » <i>Inner tubes and tires</i>   | » <i>Grips</i>               |
| » <i>Brake fluid</i>             | » <i>Cables/connectors</i>   |
| » <i>Brake disc rotors</i>       | » <i>Pedals</i>              |
| » <i>Bearings</i>                |                              |

## **Battery**

If the battery fails completely during the first 24 months or 500 cycles (whichever comes first) from the original date of purchase, it will be replaced or repaired at no charge. Lithium batteries require care and some maintenance to maximize life expectancy (please read chapter Battery life). Abusing the battery will void your warranty.

### **The warranty is void in the following cases:**

- |                                                                                                           |
|-----------------------------------------------------------------------------------------------------------|
| » <i>if damage is caused by power surge;</i>                                                              |
| » <i>if damage is caused by the use of an improper charger;</i>                                           |
| » <i>if damage is caused by improper maintenance or other such misuse;</i>                                |
| » <i>if damage is caused by normal wear;</i>                                                              |
| » <i>if damage is caused by water damage;</i>                                                             |
| » <i>if the battery is charged below 0°C [32°F];</i>                                                      |
| » <i>if the battery is below 20% of its capacity and not charged in the period longer than one month.</i> |

If a battery needs to be removed for return shipment to Greyp, it is the customer's responsibility to safely remove and send the battery to Greyp at their own cost. Greyp will reimburse the customer for its own labour & replacement parts in the first 24 months of bike ownership.

Greyp will pay to return the battery to the customer. Greyp retains the right to repair or replace battery at its sole discretion. All lithium batteries must be shipped as Class 9 dangerous goods (HAZMAT) and must be shipped in accordance with all local and international laws. Lithium batteries sold by Greyp can and should NEVER be taken on board a passenger aircraft.

## **Frame**

The Greyp frame is covered by a warranty against defects for 24 months from the original date of purchase for the original owner. If a frame is found to be defective, EU shipping, parts and labour to replace the frame is paid by Greyp for the first 24 months from the original date of manufacture. The cost of repairing/replacing custom paint is never included in frame warranty at any time.

## **Motor**

The motor is warranted for 24 months from the original date of purchase to be free from defects. In the event of a warranty claim requiring the motor to be returned to Greyp, the customer is responsible for the removal and shipment to Greyp. Greyp pays for the parts, in-house labour and the return shipping.

## **Electronics**

The electronics components are warranted for 24 months from the original date of purchase to be free from defects. In the event of a warranty claim requiring the electronics to be returned to Greyp, the customer is responsible for removal and shipment to Greyp. Greyp pays for parts, in-house labour and the return shipping.

## **Brakes**

The brakes are warranted for 24 months from the original date of purchase to be free from defects. Normal wear of the brake pads and brake disc rotors is not covered. Warranty claims on components are made in accordance with the component manufacturer's guidelines. In the event of a warranty claim requiring the components to be returned to Greyp, the customer is responsible for the removal and shipment to Greyp. Greyp pays for parts, in-house labour and return shipping.

## **Suspension**

The suspension units are warranted for 24 months from the original date of purchase to be free from defects. Normal wear of the suspension, such as oil changes and leaking seals are not covered. Warranty claims for components are made in accordance with the component manufacturer's guidelines. In the event of a warranty claim requiring the components to be returned to Greyp, the customer is responsible for the removal and shipment to Greyp. Greyp pays for parts, in-house labour and the return shipping.

## Drivetrain

The drivetrain includes the sprockets, shifting system, chain and wheels. Drivetrain units are warranted for 24 months from the original date of purchase to be free from defects. Normal wear and tear of the drivetrain, such as chain and sprocket wear, tire flats, bent wheels, spokes, hubs, free hubs, bearings and worn tires are not covered. Warranty claims for components are made in accordance with the component manufacturer's guidelines. In the event of a warranty claim requiring the components to be returned to Greyp, the customer is responsible for the removal and shipment to Greyp. Greyp pays for parts, in-house labour and return shipping.

## How to file a claim

Greyp Bikes d.o.o. will not provide any warranty coverage unless claims are made in compliance with all the Greyp Bikes d.o.o. Warranty Terms and Conditions and the proper return procedure is not followed. To request a warranty service, the Greyp Customer Service Department needs to be contacted and the following information needs to be clearly provided:

- » *the sales receipt or other evidence of the date and place of purchase;*
- » *full name, contact details (including telephone number and email address);*
- » *build number of the bike;*
- » *a description of the problem;*
- » *images or video evidence of the problem;*
- » *delivery of the product or the defective part, postage prepaid and carefully packed and insured, to Greyp Bikes d.o.o. or an agreed dealer.*

The product or defective part has to be delivered to Greyp Bikes d.o.o. or an agreed dealer postage prepaid and carefully packed and insured. When the warranty service is completed, any repaired or replacement product or part will be returned to the customer postage prepaid. Greyp Bikes d.o.o. reserves the right to inspect any defective components or products to determine whether a repair or replacement is required.

Greyp Bikes d.o.o., Ljubljanska 7, 10431 Sveta Nedelja, Croatia

# 7

## Disposal

---

The drive unit, on-board computer including the operating unit, battery pack, speed sensor, accessories and packaging should be disposed of in an environmentally correct manner.

### **Only for EC countries:**

According to the European Guideline 2012/19/EU, electrical devices/tools that are no longer usable, and according to the European Guideline 2006/66/EC, defective or used battery packs / batteries, must be collected separately and disposed of in an environmentally correct manner.

Please return the battery packs and on-board computers that are no longer usable to an authorised bicycle dealer.

Batteries and chargers must not be disposed in your household trash! All batteries and chargers must be disposed in an environmentally friendly manner, in accordance with the battery disposal regulations in your country or state. Ask your authorized Greyp retailer for information on how to dispose a battery or charger and any applicable take-back programs.

S  
E  
R  
E  
S  
T-

**BIKE**

**USER**

**MAN-**

**UAL**

ENGLISH

READ  
BEFORE  
YOUR  
FIRST  
RIDE







# TECHNICAL MANUAL – T-SERIES

---

ENGLISH

# Contents

---

<b>1</b>	<b>INTRODUCTION</b>	<b>3</b>	Assist level up/down	<b>18</b>
	Greyp Bikes Disclaimer	<b>3</b>	Info and pair a bike screen	<b>19</b>
	General warning	<b>4</b>	Manual software update	<b>19</b>
	General information	<b>4</b>	Manual software update	<b>20</b>
	Out of box assembly	<b>6</b>	Battery pack mount	<b>21</b>
	EU specifics	<b>9</b>	Battery pack dismount	<b>21</b>
	USA specifics	<b>9</b>	Appropriate spares	<b>22</b>
<b>2</b>	<b>GENERAL NOTES ABOUT RIDING</b>	<b>10</b>	<b>4 BIKE MAINTENANCE AND RANGE</b>	<b>23</b>
	Front suspension	<b>10</b>	Service and maintenance schedule	<b>23</b>
	Additional adjustment	<b>10</b>	Shifting recommendations	<b>25</b>
	Recommended tire pressure	<b>10</b>	Frame torque specification	<b>25</b>
<b>3</b>	<b>SYSTEM FUNCTIONS</b>	<b>13</b>	Handlebar parts / stem / torque specification	<b>27</b>
	Bike parts	<b>13</b>	Luggage carrier torque specification	<b>28</b>
	Control unit functions	<b>14</b>	Front fork / front mudguard torque specification	<b>29</b>
	Display unit information	<b>15</b>	Luggage carrier mounting	<b>29</b>
	Power on	<b>16</b>	Cable routing	<b>30</b>
	Stand by mode on	<b>16</b>	<b>5 EC – DECLARATION OF CONFORMITY</b>	<b>31</b>
	Stand by mode off	<b>16</b>		
	Power off	<b>17</b>		
	Walk assist mode	<b>17</b>		
	Lights on/off	<b>17</b>		
	Joystick	<b>18</b>		

# 1

## Introduction

**Original instructions (user manual/instructions for use) are written in English. All other languages are translations of the original instructions (user manual/instructions for use). In case of any dispute, the user manual in English prevails. Greyp bikes user manual (instructions for use) comes in 2 parts. This book called "TECHNICAL MANUAL" and other book called "GENERAL MANUAL". If you didn't get one of them please ask shop to send you one or download one from official Greyp web site.**

This user instruction manual is developed for your Greyp bike only. It contains important safety, performance and technical information, which you should read before your first ride and keep for reference. You should also read the entire User Manual, because it contains additional important general information and instructions that you should follow.

*If you do not have a copy of the User Manual, please download it for free at [www.greyp.com](http://www.greyp.com) or obtain it from your nearest Authorised Greyp Retailer. In case of discrepancy, the english version shall prevail.*

### Greyp Bikes Disclaimer

Any modifications of the bike are strictly forbidden and Greyp Bikes d.o.o. will bear no liability whatsoever for the consequences of such modifications. Greyp Bikes d.o.o. does not grant, explicitly or implicitly, to any party any patent rights, licenses or any other IP rights, whether with regard to such information itself or to anything described by such information. The information provided by Greyp Bikes d.o.o. hereunder is provided *as is, where is* and with all faults, and the entire risk associated with such information is entirely with the buyer. The information provided in this document is proprietary to Greyp Bikes d.o.o., and Greyp Bikes d.o.o. reserves the right to make any changes to the information in this document or to any products and services at any time without notice.

You should check [www.greyp.com](http://www.greyp.com) for any changes made in the User Manual.



**Greyp Bikes d.o.o.,**  
Ljubljanska 7, 10431 Sveta Nedelja, Croatia,  
15<sup>th</sup> of February 2020.

## General warning

This manual contains many "WARNINGS" and "CAUTIONS" concerning the consequences of failure to maintain or inspect your bike and of failure to follow safe cycling practices.

The combination of the safety alert symbol and the word WARNING indicates a potentially hazardous situation which, if not avoided, could result in serious injury or death.

The combination of the safety alert symbol and the word CAUTION indicates a potentially hazardous situation which, if not avoided, may result in minor or moderate injury, or is an alert against unsafe practices.

Many of the WARNINGS and CAUTIONS say *you may lose control and fall*. Because any fall can result in serious injury or even death, we do not always repeat the warning of possible injury or death.

As it is impossible to anticipate every situation or condition which can occur while riding, this User Manual makes no representation about the safe use of the bicycle under all conditions. There are risks associated with the use of any bicycle which cannot be predicted or avoided, and which are the sole responsibility of the rider.

## General information

» **EU** - The T5.1 and T5.2 are high-performance bicycles.

» **US** - The T5.1 (US) and T5.2 (US) are CLASS 1 electric bicycle.

T-series bicycles are suitable and intended for well-maintained hard-surface roads where the wheels remain in permanent contact to the ground. These bikes are designed for urban mobility and thus mainly for participation in road traffic and use on public and permitted lanes. For other Greyp bikes, please check the pertinent information with your local retailer.

Motor support will automatically switch off when you reach a maximum speed of: 25km/h for T5.1 and T5.2; 32km/h (20mph) for T5.1(US) and T5.2(US). A driver's license or insurance is typically not required. Regardless of its classification, the bike will only provide motor support only while pedaling.

## THE MAXIMUM PERMISSIBLE WEIGHT



<b>VEHICLE</b>	<b>THE PERMISSIBLE TOTAL PAYLOAD WEIGHT (DRIVER + LUGGAGE) *</b>	<b>VEHICLE WEIGHT **</b>	<b>MAXIMUM PERMISSIBLE TOTAL WEIGHT (VEHICLE + DRIVER + LUGGAGE)</b>
<b>T5.1 AND T5.1(US)</b>	112.3 kg [248 lb]	27.7 kg [61 lb]	140 kg [309 lbs]
<b>T5.2 AND T5.2(US)</b>	112.5 kg [248 lb]	27.5 kg [61 lb]	140 kg [309 lbs]

Please find additional safety, performance and service information for specific components such as suspension, brakes or motor in the Manufacturer's Guidelines.

\* Frame size M has a higher Permissible Total Payload Weight by up to 0.2kg while frame size XL has the Permissible Total Payload Weight lower by up to 0.2kg, than what is listed in the table.

\*\* Frame size M is up to 0.2kg lighter while frame size XL is up to 0.2kg heavier than listed in the table.

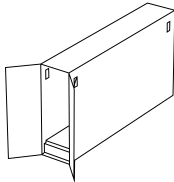
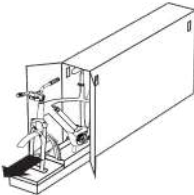
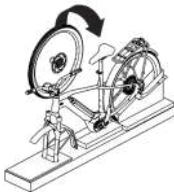
## Out of box assembly

1	OPEN BOX	2	BIKE OUT	3	FRONT WHEEL	4	TOOL BOX
							
	Open the marked side of the box	Pull out the bike holding the fork	Take out the front wheel	Lift the bike to access the toolbox			

If you don't have the knowledge or ability to assemble the Greyp yourself, please consult a professional mechanic.

## 5 HANDLEBAR POSITIONING

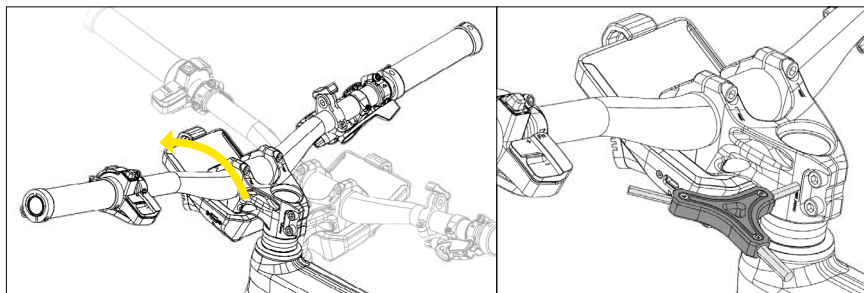

1. Rotate the handlebar to its natural position ( $\approx 90^\circ$  to the frame, "centered").
2. Using the tool (three-arm hex key number 5), **lightly tighten the two bolts** on the stem.

## 6

## FRONT WHEEL MOUNTING

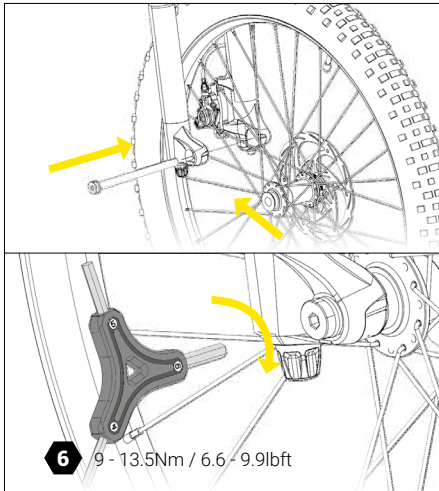

**1.** Guide your **wheel into the fork** and guide the rotor between the brake pads.

**2. Tighten the axle** - line up your hub with the holes at the bottom of your fork. Check which side of the fork is threaded and push the axle in from the opposite side. Turn the three-arm hex key number 6 clockwise to thread the axle into the fork.

## TOOLS

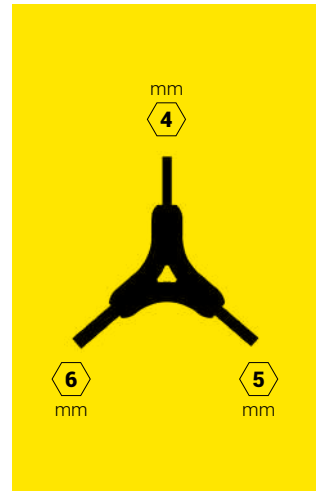

## 7

## PEDALS MOUNTING

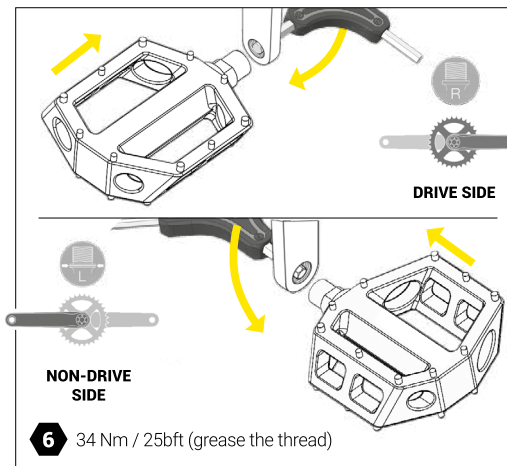

**1.** Take the pedals out of the box, **grease the thread and tighten** them using the tool (three-arm hex key number 6) (see picture above).

**2.** Pay attention to the **direction of rotation** while tightening. The thread on the right pedal is right-handed (standard). The direction of rotation for tightening is anti-clockwise. The thread on the left pedal is left-handed so the direction of rotation for tightening is clockwise.

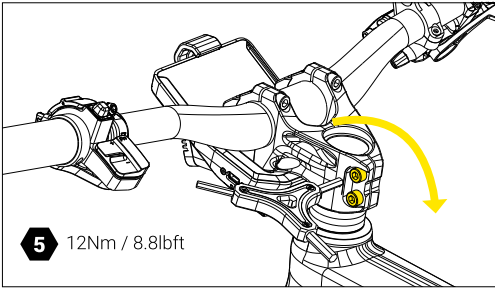

**1. Slightly loosen the 2 bolts on the stem.**

Tighten the top cap (headset bolt) to 6Nm using the three-arm hex key number 5.

**2. Center and tighten** the 2 bolts on the stem. The easiest way to get everything "centered" is to stand in front of your bike and hold the front wheel between your feet and legs. Tighten the 2 bolts on stem (headset bolt) to 12Nm.

**Grab the front brake and use the bars to push/jolt the bike forward.** If you feel that the headset is loose (a clinking sound, or any movement other than the rear wheel coming off the ground), loosen the 2 bolts on the stem and tighten the top cap, but be careful how much you tighten it (three-arm hex key number 5). The top cap bolt will determine how loose or tight your headset is, so it plays a major role in the steering and feel of your bike. Tighten the bolt a little at a time and between each turn.

Once the looseness in the headset is gone, it should be tight enough. **Give the handlebar a turn to the left and right** to make sure they still move smoothly. If the movement is tight, you've gone too far. Back the stem cap off a quarter to half a turn and try again. Once there is no looseness in the headset and the handlebar is smoothly turning, you need to take the tool (three-arm hex key number 5) and tighten the two bolts on the stem (see picture).

**Flip your bike over and spin your wheel:** by spinning your wheel, you will make sure your brake pads are not rubbing on the rotor. If your wheel does not spin, it could be crooked in the fork's dropouts. Flip your bike back, loosen your axle, push down on the wheel and tighten the axle again.



## EU SPECIFICS

	<b>RADIO FREQUENCY BAND</b>	<b>MAXIMUM RADIO-FREQUENCY POWER</b>
1	EGSM900	35 DBM
2	GSM1800	32 DBM
3	GSM 900 8-PSK	30 DBM
4	GSM 1800 8-PSK	29 DBM
5	LTE FDD BD1, BD3, BD7, BD8, BD20	25 DBM
6	UMTS WCDMA FDD BDI, BDIII, BDVIII	25 DBM
7	WIFI 4.9 GHZ TO 5.8 GHZ	18 DBM
8	WIFI 2.4 GHZ TO 2.5 GHZ	18 DBM
9	BLUETOOTH 2.4 GHZ	12 DBM

## USA SPECIFICS

This device complies with part 15 of the FCC Rules. Operation is subject to the following two conditions: (1) This device may not cause harmful interference, and (2) this device must accept any interference received, including interference that may cause undesired operation.

Contains FCC IDs: QIPPLS8-USR4, Z64-WL18SBMOD

**NOTE** – This equipment has been tested and found to comply with the limits for a Class B digital device, pursuant to part 15 of the FCC Rules. These limits are designed to provide reasonable protection against harmful interference in a residential installation. This equipment generates, uses and can radiate radio frequency energy and, if not installed and used in accordance with the instructions, may cause harmful interference to radio communications. However, there is no guarantee that interference will not occur in a particular installation. If this equipment does cause harmful interference to radio or television reception, which can be determined by turning the equipment off and on, the user is encouraged to try to correct the interference by one or more of the following measures:

- » *Reorient or relocate the receiving antenna;*
- » *Increase the separation between the equipment and receiver;*
- » *Connect the equipment into an outlet on a circuit different from that to which the receiver is connected;*
- » *Consult the dealer or an experienced radio/TV technician for help.*



**CAUTION** - Changes or modifications not expressly approved by the party responsible for compliance could void the user's authority to operate the equipment.

# 2

## General notes about riding

### SUSPENSION

#### Front suspension

Rebound damping controls the suspension fork extension/return speed, which affects traction and control. Optimal rebound damping allows the fork to extend at a controlled speed and maintain traction and control. Rebound that is too fast allows the fork to extend too quickly, which causes the wheel to bounce off objects and the ground resulting in a pogo effect. Rebound that is too slow prevents the fork from extending quickly enough to regain contact with the ground or prepare for the next impact. Rebound damping can be tuned to rider weight, spring rate and travel, as well as for terrain and rider preference. As the air pressure or spring rate increases, the extension/return speed increases. To achieve the optimal setting, rebound damping may need to be increased when air pressure or spring rate increases.

#### Additional adjustment

Depending on the exact model of the fork, there are various adjustments that can be made, and some of them are rebound, low speed compression, high speed compression, lockout and other. For further information please contact your Greyp dealer or visit fork manufacturers website. Usually on fork crown there is level or nut adjuster which if you rotate you can make fork absorption softer or harder.

#### Recommended tire pressure



**WARNING** — If the maximum pressure values in this manual and values on the side wall of a tire are in any way different, please refer to the ones that are marked on the tire's sidewall or wheel (whichever is lowest). Never inflate a tire beyond the maximum pressure marked on the tire's sidewall. Exceeding the recommended maximum pressure may blow the tire off the rim, which could cause damage to the bike and injury to the rider and/or bystanders.

## MAXIMUM TIRE PRESSURE

BIKE	FRONT TIRE	REAR TIRE
T5.1	3.7 bar (54 psi)	3.7 bar (54 psi)
T5.2	3.7 bar (54 psi)	3.7 bar (54 psi)

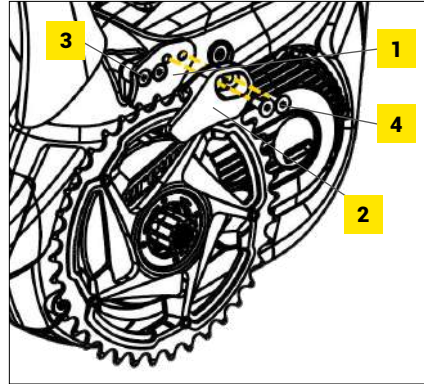
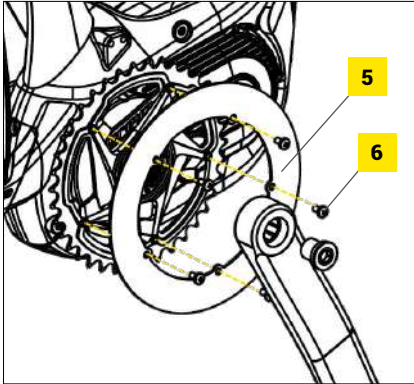

**Chainguide – use only with positive foot-retention devices on the pedals**

## CHAINGUIDE OR CHAINGUARD MOUNT

	NAME/DESCRIPTION	TORQUE, Nm [lbf ft]
1	CHAINGUIDE ALUMINUM PART	-
2	CHAINGUIDE PLASTIC PART	-
3	DIN 7991 M5X18	4 [3] + low strength threadlocker
4	DIN 7991 M5X12	4 [3] + low strength threadlocker
5	CHAINGUARD	-
6	ISO 7045 M4X8	4 [3]

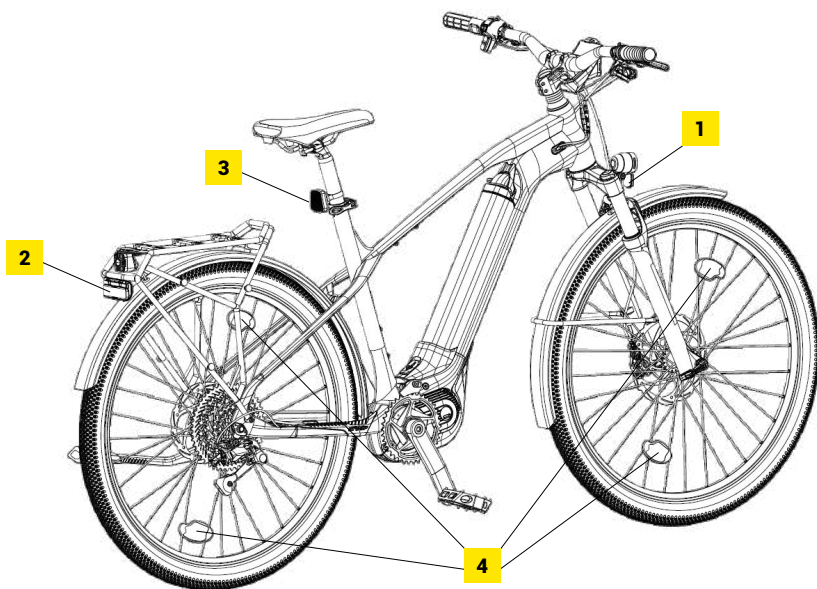

## REFLECTORS

	NAME/DESCRIPTION
1	FRONT REFLECTOR 313/5K
2	REAR REFLECTOR 314/1
3	REAR REFLECTOR 313/1ZB
4	SPOKE REFLECTOR 309 (M); (US - RR-530-WUW)

# 3

## System functions

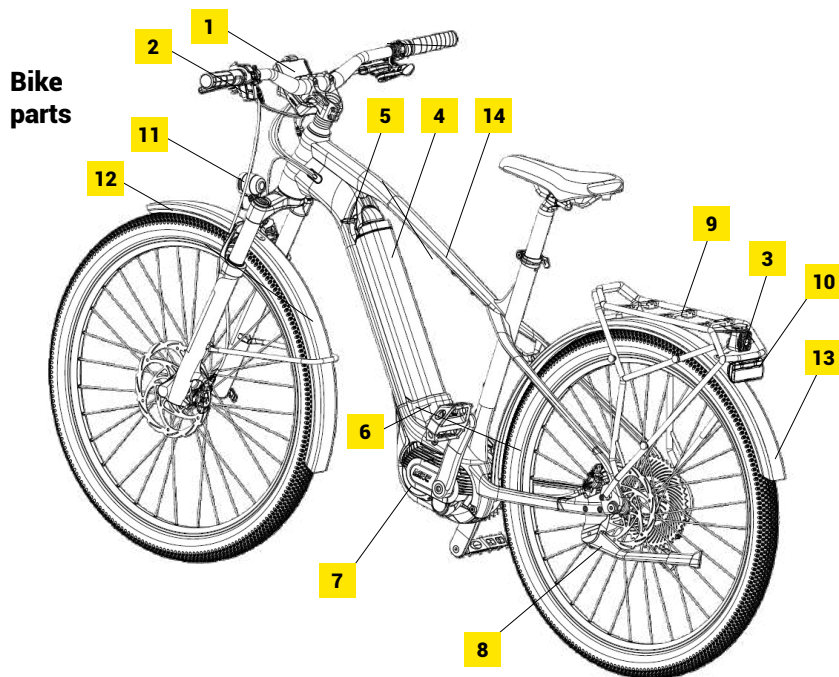

### BIKE PARTS

#### NAME/DESCRIPTION

1	DISPLAY UNIT (CIM)	8	KICKSTAND
2	CONTROL UNIT (CBC)	9	LUGGAGE CARRIER
3	REAR CAMERA (BUTS)	10	REAR LIGHT (Busch+Müller)
4	BATTERY	11	FRONT LIGHT (Busch+Müller)
5	BATTERY LOCK	12	FRONT MUDGUARD
6	PUSHPLATE	13	REAR MUDGUARD
7	MOTOR	14	FRAME

## Control unit functions

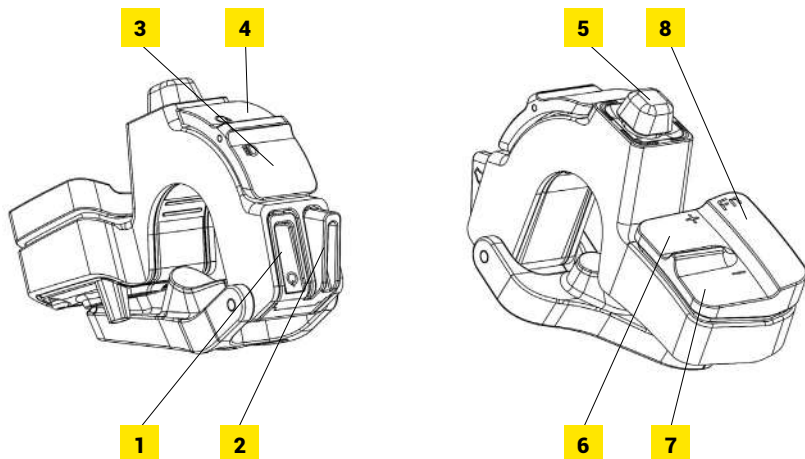

### LEGEND

NAME/DESCRIPTION	ICON	FUNCTION	TYPE
1 POWER		ON/OFF AND STAND BY	LONG/SHORT PRESS
2 WALK ASSIST		WALK ASSIST	PRESS & HOLD
3 LIGHT		TURN ON/OFF FRONT AND REAR LIGHTS	SHORT PRESS - Busch+Müller lights (see bike parts 10 & 11) LONG PRESS - auxiliary Greyp lights (on CIM and BUTS, see bike parts 1 & 3)
4 RETRO VIDEO		RECORDS THE LAST 30 SECONDS OF YOUR RIDE	
5 JOYSTICK		SWITCH BETWEEN DISPLAY FUNCTIONS	SHORT PRESS IN ALL DIRECTIONS
6 ASSIST LEVEL UP		INCREASE LEVEL OF ASSISTANCE	SHORT PRESS
7 ASSIST LEVEL DOWN		DECREASE LEVEL OF ASSISTANCE	SHORT PRESS
8 FUNCTION		VARIOUS FUNCTIONALITIES (SEE NEXT PAGES)	

## Display unit information

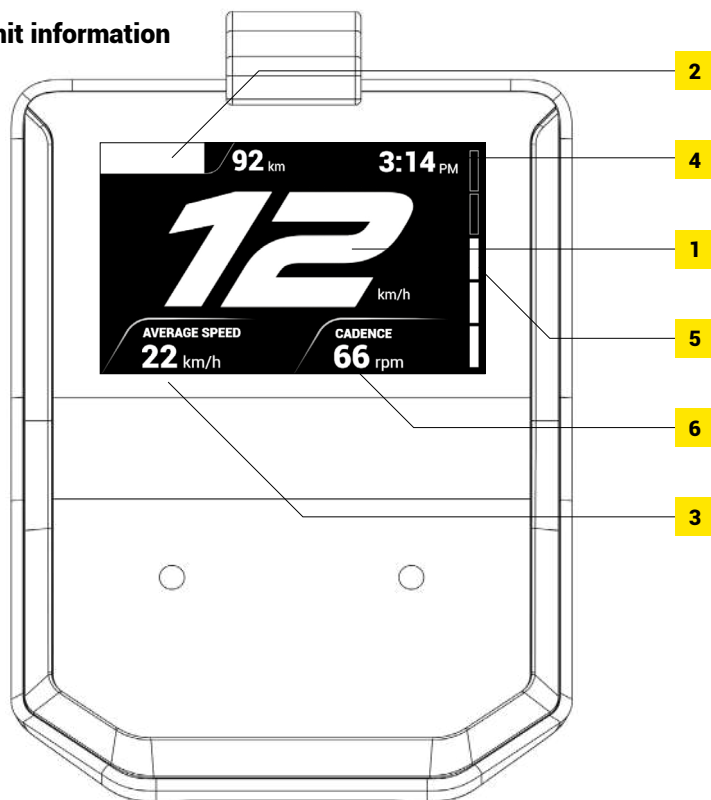

### CIM DISPLAY INTERFACE

#### NAME/DESCRIPTION

- |   |                                     |
|---|-------------------------------------|
| 1 | SPEED                               |
| 2 | BATTERY CHARGE / REMAINING DISTANCE |
| 3 | RIDE STATISTICS                     |
| 4 | TIME                                |
| 5 | ASSISTANCE LEVEL                    |
| 6 | CADENCE                             |

## Power on



To turn on the bike, long press the power button

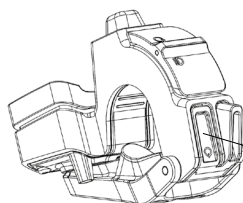

Long press

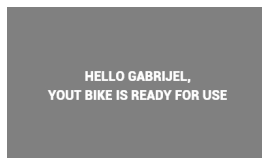
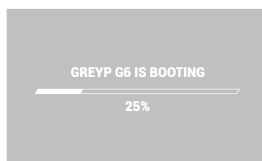

## Stand by mode on



To put your bike in standby mode, short press the power button

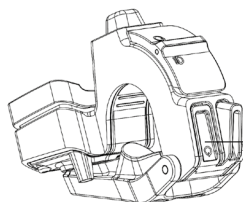

Short press

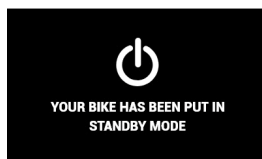

## Stand by mode off

To wake up the bike from stand-by mode, press any button on the control unit or move the bike

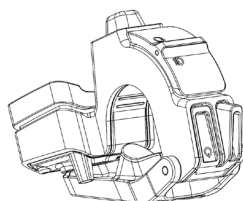

Press any button





## Power off



To turn off the bike,  
long press the power button

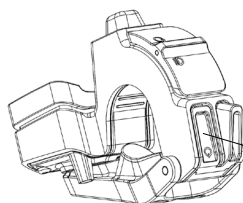

**Long press**



YOUR BIKE HAS BEEN  
TURNED OFF

## Walk assist mode



To activate the walk assistance mode,  
press and hold walk assist button

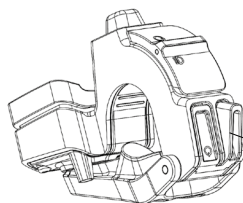

**Press and hold**

## Lights on/off



To turn the lights on or off,  
short or long press the light button

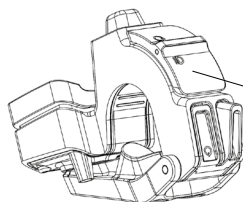

**SHORT PRESS - Busch+Müller lights  
(see bike parts 10 & 11)**

**LONG PRESS - auxiliary Greyp lights  
(on CIM and BUTS, see bike parts 1 & 3)**

## Joystick



To switch between different information on the display unit, move the joystick up or down

- » TRIP
- » ODOMETER
- » AVERAGE SPEED
- » TRIP TIME

Move up/down

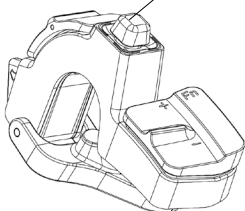

## Assist level up/down



To change the assistance level, short press the plus or minus assist level button

Short press to change by one level

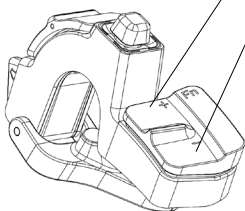

## Info and Pair a bike screen

To access the Info screen, use a combination of buttons.

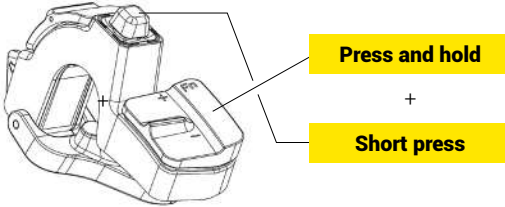

Move the joystick up or down to scroll inside the screen or move the joystick left/right to switch between screens

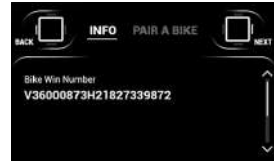
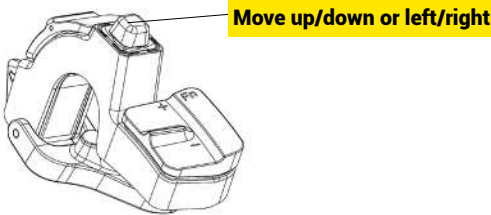

## Manual Software Update

**Fn** +  To start the software update use a combination of buttons. Make sure your bike is connected to a charger and that it is connected to your personal hot spot.

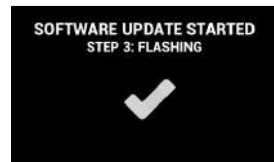
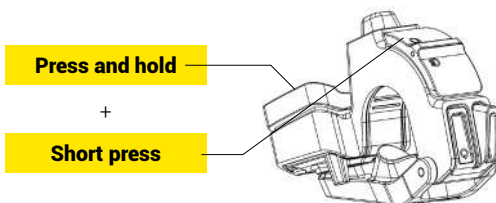

## Retro video

---

-  Records the last 30 seconds of the ride on your bike. Download your Retro Videos using the Greyp App.

Find out more about Retro video in the [App manual](#).

---

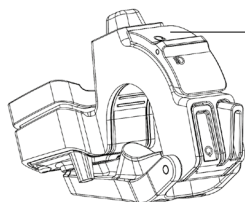

**Short press**



## Battery pack mount

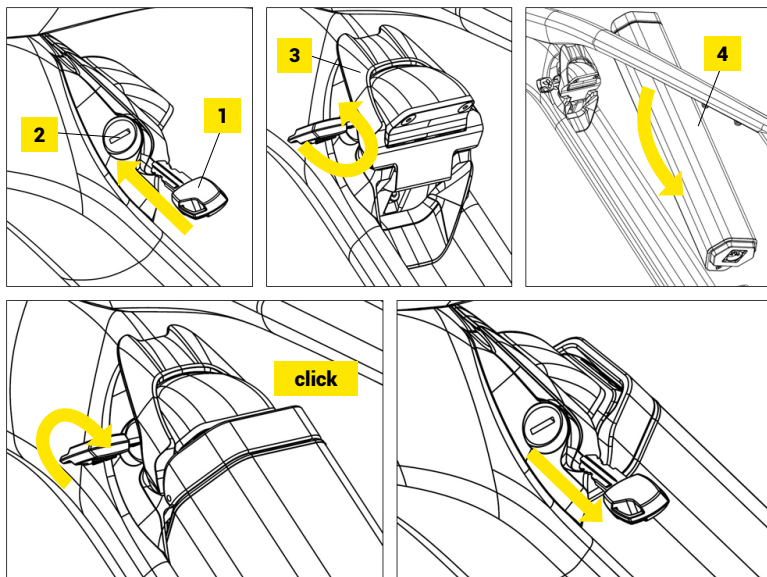

## Battery pack dismant

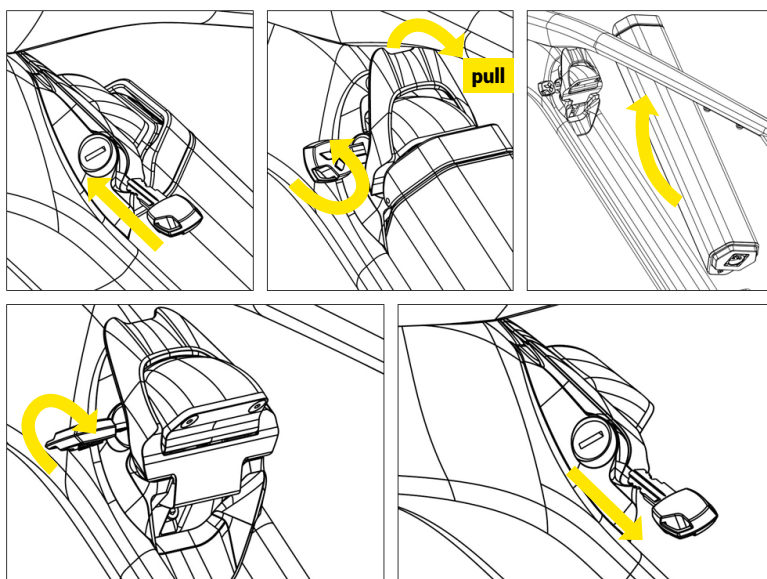

## **BATTERY PACK MOUNT/DISMOUNT**

### **NAME/DESCRIPTION**

- 1 BATTERY LOCK KEY
- 2 BATTERY LOCK
- 3 BATTERY LOCK HANDLE
- 4 BATTERY PACK

### **Appropriate spares:**

<b>BIKE</b>	<b>FRONT &amp; REAR TIRE</b>	<b>BRAKES</b>	<b>ROTORS</b>	<b>INNER TUBE</b>
T5.1	29" x 2.25"	Formula Cura or Cura 4	six-bolt 203mm front & 180mm rear	according to outside tire dimensions
T5.2	29" x 2.25"	Formula Cura or Cura 4	six-bolt 203mm front & 180mm rear	according to outside tire dimensions

# 4

## Bike maintenance and range

### Service and maintenance schedule

COMPONENT	WHAT TO DO	BEFORE EVERY RIDE	MONTHLY	ANNUALLY	OTHER
CHAIN	Check and lube if necessary	X			
CHAIN	Replace				After 1000km or sooner if needed
CASSETTE AND CHAIN RING	Replace				After 3000km or sooner if needed
TIRES	Check pressure, tread and side walls	X			
TIRES					After 3 years or at wear mark
INNER TUBES	Replace			X	
FRONT AND REAR HUB BEARINGS	Check for play		X		
BRAKE PADS	Check for wear	X			
BRAKE PADS	Replace			X	
BRAKE DISC ROTOR	Check for wear and trueness	X			
BRAKES	Check for leaks	X			
BRAKE FLUID	Change				As specified by manufacturer

<b>SUSPENSION</b>	Service				As specified by manufacturer
<b>BOLTS AND NUTS</b>	Check and tighten if necessary		X		
<b>CABLES AND HOUSINGS</b>	Replace			X	
<b>HEADSET</b>	Check for play and regrease if necessary		X		
<b>HANDLEBARS</b>	Check and replace if necessary			X	
<b>LIGHTING</b>	Check	X			
<b>PEDALS</b>	Check for play		X		
<b>THRU-AXLES</b>	Check and tighten if necessary	X			
<b>STEM</b>	Disassemble and clean			X	
<b>WHEELS/ SPOKES</b>	Check for trueness and tension		X		
<b>SEAT POST</b>	Disassemble, clean and put sand paste (for carbon) on contact with frame			X	
<b>SHOCK SCREWS</b>	Disassembly, clean and put silicone paste on contact with frame				After 1000 km or sooner if needed
<b>DROPOUT</b>	Disassemble, clean and put silicone paste on contact with frame			X	After 300 km or sooner if needed
<b>MOTOR SCREWS</b>	Disassemble, clean and put silicone paste on contact with frame				After 1000 km or sooner if needed
<b>MOTOR-CRANK CONTACT</b>	Disassemble, clean and put bike grease			X	



## Shifting recommendations

For better range, Greyp advises to shift according to your speed. For low speeds, low gearing is best. The higher the speed, the higher the gear that can be chosen. For smooth support and optimum range, it is best to release the pedal pressure while shifting gears.

**Only shift one gear at time. When shifting gear make sure you release power and pedal very lightly during the whole duration. Shifting a gear under power or more gears at the same time can cause premature wear and damage to your drivetrain.**

- » *high speed, high gear*
- » *low speed, low gear*
- » *release power on pedals during shifting*

## Frame torque specification

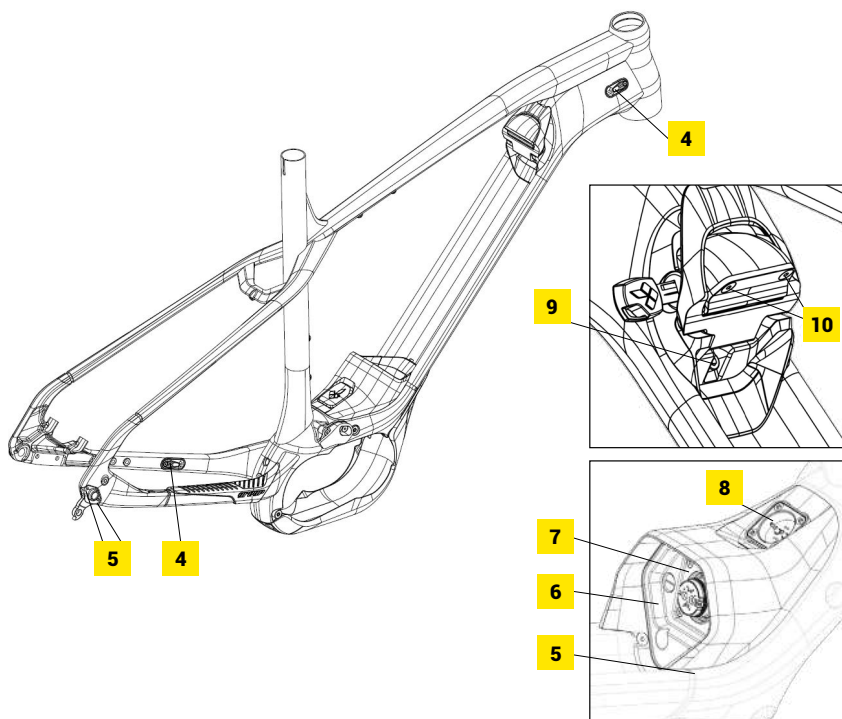

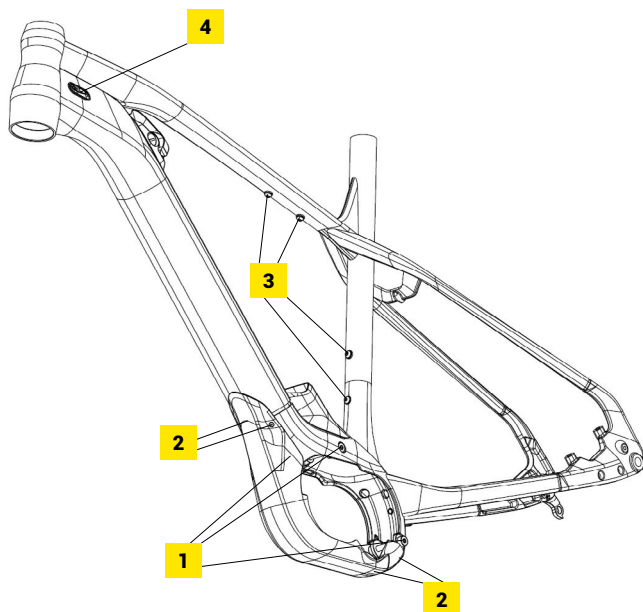

### FRAME TORQUE SPECIFICATION

	NAME / DESCRIPTION	TORQUE, Nm [lbf ft]
1	FRAME / MOTOR	10 [7.4] + medium strength thread locker
2	SKIDPLATE / FRAME	4 [3] + low strength thread locker
3	BOTTLE CAGE / FRAME	2 [1.5]
4	CABLE GLAND / FRAME	1 [0.7] + low strength thread locker
5	PUSHPLATE HOLDER / FRAME	2 [1.5] + medium strength thread locker
6	PUSHPLATE / PUSHPLATE HOLDER	4 [3] + low strength thread locker
7	Y-WIRING / PUSHPLATE	1 [0.7]
8	Y-WIRING / PUSHPLATE HOLDER	1 [0.7]
9	BATTERY LOCK HOUSING / FRAME	3 [2.2] + medium strength thread locker
10	BATTERY LEVER / BATTERY LOCK HOUSING	2 [1.5] + medium strength thread locker

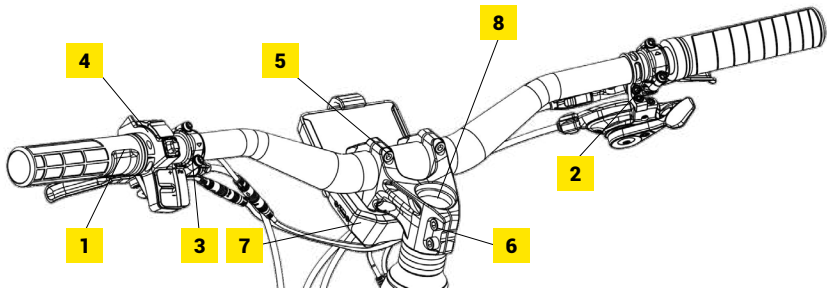

### HANDLEBAR PARTS / STEM / TORQUE SPECIFICATION

	NAME / DESCRIPTION	TORQUE, Nm [lbf ft]
1	GRIPS / HANDLEBAR	2 [1.5]
2	SHIFTER / HANDLEBAR	4 [3]
3	BRAKE LEVERS / HANDLEBAR	4 [3]
4	CBC / HANDLEBAR	0.5 [0.37] + low strength thread locker
5	STEM / HANDLEBAR	9 [6.6] + low strength thread locker
6	STEM / FRONT FORK	12 [8.9] + low strength thread locker
7	CIM / STEM	1 [0.7], MAX <2 [1.5]
8	HEADSET / FRONT FORK	6 [4.4]

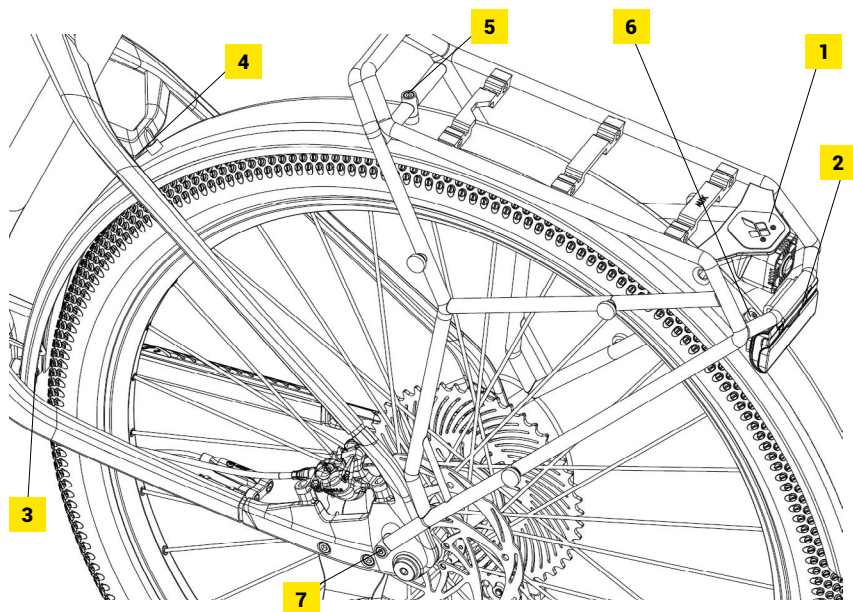

### LUGGAGE CARRIER / REAR MUDGUARD TORQUE SPECIFICATION

NAME/DESCRIPTION		TORQUE, NM [LBF FT]
1	REAR CAMERA (BUTS) / LUGGAGE CARRIER	1 [0.7] + medium strength thread locker
2	REAR LIGHT PLATE / REAR LIGHT	4 [3]
3	REAR MUDGUARD / FRAME (MOTOR)	4 [3] + medium strength thread locker
4	REAR MUDGUARD / FRAME (SEATSTAY BRIGDE)	4 [3] + medium strength thread locker
5	REAR MUDGUARD / LUGGAGE CARRIER	4 [3] + medium strength thread locker
6	REAR MUDGUARD / REAR LIGHT PLATE	4 [3] + medium strength thread locker
7	LUGGAGE CARRIER / FRAME	8 [5.9] + medium strength thread locker

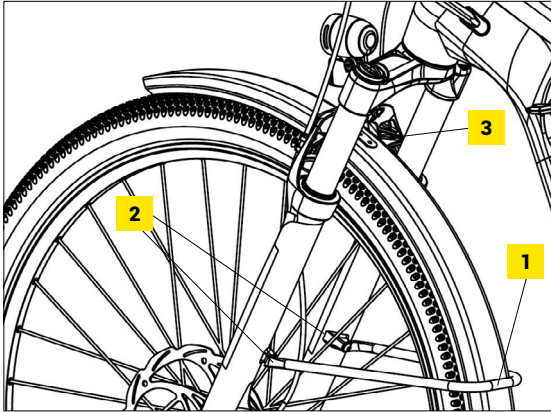

### FRONT FORK / FRONT MUDGUARD TORQUE SPECIFICATION

NAME/DESCRIPTION		TORQUE, NM [LBF FT]
1	FRONT MUDGUARD STAY / FRONT MUDGUARD	8 [5.9] + medium strength thread locker
2	FRONT MUDGUARD STAY / FORK	4 [3] + medium strength thread locker
3	FRONT MUDGUARD / FRONT LIGHT / FORK	4 [3] + medium strength thread locker

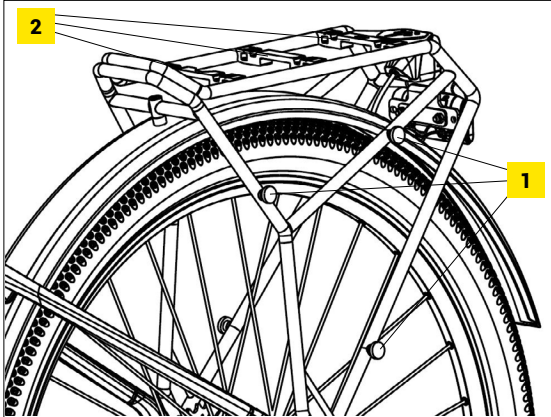

### LUGGAGE CARRIER MOUNTING

NAME/DESCRIPTION	
1	ORTLIEB MOUNTING POINTS – QL3.1 - for more information please visit <a href="https://www.ortlieb.com/en_us/">https://www.ortlieb.com/en_us/</a>
2	MIK MOUNTING POINTS – for more information please visit - <a href="https://www.mik-click.com">https://www.mik-click.com</a>

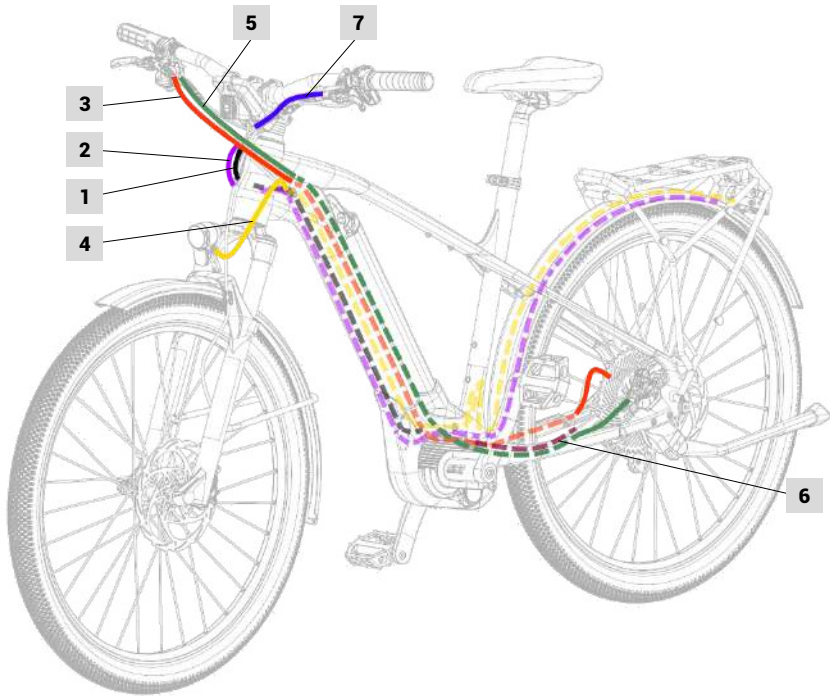

## CABLE ROUTING

### NAME/DESCRIPTION

1	CIM / Motor
2	CIM / Rear camera
3	Shifter
4	Front light / Rear light / Motor
5	Rear brake
6	Speed sensor / Motor
7	CIM / CBC

# 5

## EC – Declaration of conformity

<b>MANUFACTURER</b>	<b>GREYP BIKES D.O.O.</b>
<b>ADDRESS</b>	LJUBLJANSKA 7, 10431 SVETA NEDELJA, CROATIA
<b>DESCRIPTION OF PRODUCT</b>	GREYP T5.1 – PEDELEC (EPAC - ELECTRIC POWER ASSISTED CYCLE) GREYP T5.2 – PEDELEC (EPAC - ELECTRIC POWER ASSISTED CYCLE)
<b>NAME AND ADDRESS OF THE PERSON AUTHORISED TO COMPILE THE TECHNICAL FILE</b>	DOMAGOJ TOPLIČANEC, LJUBLJANSKA 7, 10431 SVETA NEDELJA, CROATIA
<b>THE PLACE AND DATE OF THE DECLARATION;</b>	13/06/2022, SVETA NEDELJA

**WE HEREBY EXPRESSLY DECLARE THAT THE PRODUCTS LISTED  
ABOVE FULFIL ALL THE RELEVANT PROVISIONS OF THE:**

MACHINERY DIRECTIVE (2006/42/EC), ELECTROMAGNETIC COMPATIBILITY  
(2014/30/EC), RADIO EQUIPMENT DIRECTIVE (2014/53/EU), LOW VOLTAGE  
DIRECTIVE (LVD) (2014/35/ EU), ROHS 2 DIRECTIVE (2011/65/EU)



**THE FOLLOWING HARMONIZING STANDARD WAS APPLIED TO THE T5.1 AND T5.2:**

EN 15194:2017 BICYCLES – ELECTRICALLY POWER ASSISTED CYCLES – EPAC BICYCLES.

**THE FOLLOWING STANDARD WAS USED FOR T5.1 AND T5.2:**

EN ISO 4210, EN ISO 12100:2010  
EN 62368-1:2014/AC FEB.:2015/A11:2017/ AC MAR.:2017  
EN 62311:2008, EN 301 489-1 V2.1.1 , EN 301 489-17 V3.1 1  
EN 301 489-19 V2.1.0 , EN 301 489-52 V1.1.0 ,  
EN 300 328 V2.1.1EN 301 893 V2.1.1 ,  
EN 301 511 V12.5., EN 301 908-1 V11.1.1 ,  
EN 301 908-2 V11.1.2, EN 301 908-13 V11.1.2,  
EN 303 413 V1.1.1

**Krešimir Hlede**

CEO Greyp Bikes d.o.o.

Since we are constantly working on improving our user experience, you can expect frequent mobile app updates

**FIND THE LATEST VERSION OF  
THE GREYP APP MANUAL  
ON OUR WEBSITE**

**WWW.GREYP.COM**



The Greyp mobile application is available on [\*\*Google PlayStore\*\*](#) and [\*\*AppStore\*\*](#)



**Greyp Bikes** d.o.o.

Ljubljanska 7  
10431 Sveta Nedelja  
Croatia

Tel: +385 1 409 3377

Fax: +385 1 333 6698

[info@greyp.com](mailto:info@greyp.com)

**GREYP** 